

Artikel-Nr. SToxxparts	d1 mm	d2 mm	d3 mm	d4 mm	l1 mm	l2 mm	l3 mm	w (Ausrastweg) mm	b mm	t1 mm	t2 mm
05000667001	44	10	33	33	37	6	31	4	3	11.4	1.4
05000667002	44	12	33	33	37	6	31	4	4	13.1	1.1
05000667003	52	12	42	41.8	37.5	6	31.5	4	4	13.1	1.1
05000667004	52	14	42	41.8	37.5	6	31.5	4	5	15.3	1.3
05000667005	52	16	42	41.8	37.5	6	31.5	4	5	17.3	1.3

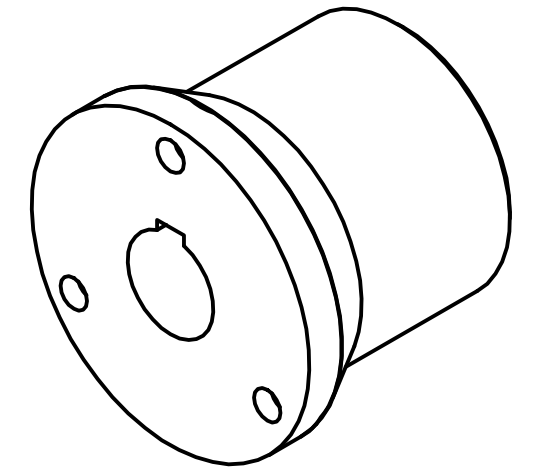

Nabennut P9 DIN 6885
 Bezugsstrich auf Arretierteil
 Edelstahl 1.4305, nichtrostend
 Skala eingraviert in Laserpräzision

STOXX parts				tolerance DIN2768-mk	
...der Normteiler					
	Datum	Name		Edelstahlarretierelement mit Skala 0...50, 60 Teilstriche	
	Gezeichnet	25.01.2021 Dennis Bruder			
	Kontroll				
	Norm				
REVISIONSVERLAUF				05000667000	
Rev.	Änderungstext	Änderungsdatum	Änderungsstamm	Gen.	1
	Erstfreigabe			PJ	A3
weight -				scale 1:1	

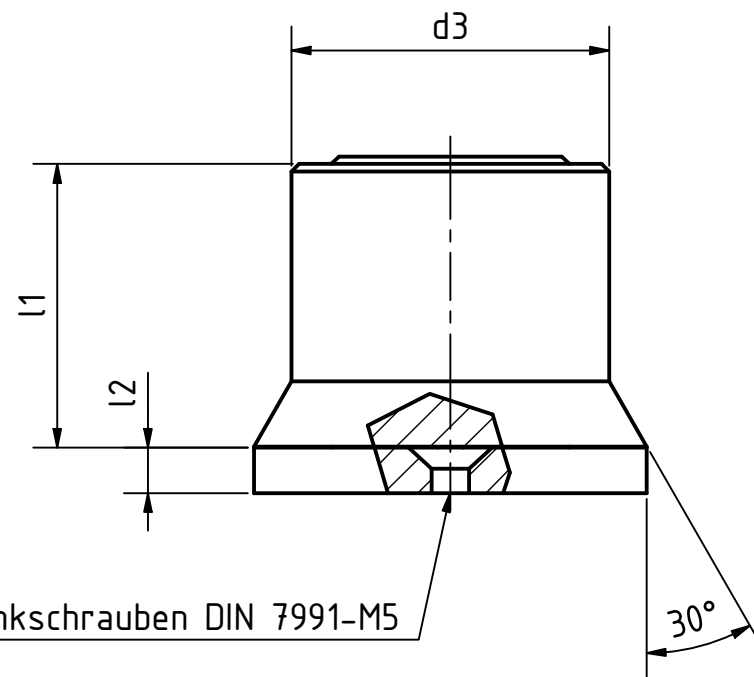
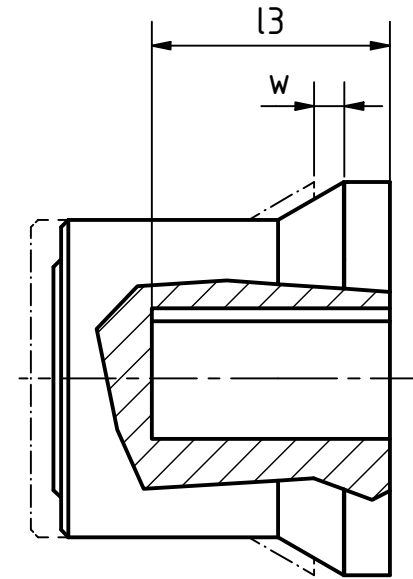
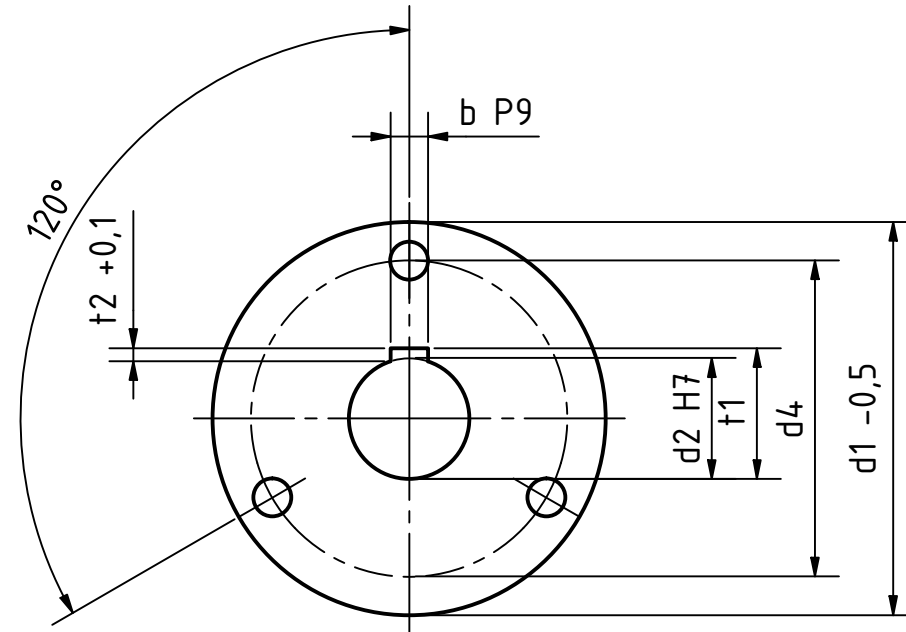