

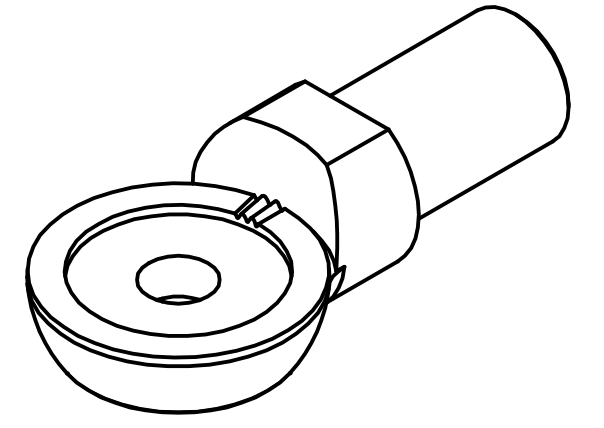

6	1			5	1			4
Zubehör	Artikel-Nr. SToxxparts							
Rastgelenkset	18001076000							
Rastscheiben	05000938000	05000939000	05000940000 (Edelstahl)					
	05001208000	05001209000	05001210000 (Stahl)					
Edelstahl Druckfeder	05000646000							

Artikel-Nr. SToxxparts	d1 mm	z (Zähneanzahl)	d2 mm	d3 mm	d4 mm	l1 mm	l2 mm	h1 (Zahnmitte) mm	h2 mm	h3 mm	SW1 mm	SW2 mm	w (Ausrastweg) min. mm
05000669001	27	48	9	18	13	21	20	8	16	3	14	12	0.8
05000669002	27	60	9	18	13	21	20	8	16	3	14	12	0.8
05000669003	32	48	9	21	16	26	24	9.5	19	3	17	12	0.8
05000669004	32	60	9	21	16	26	24	9.5	19	3	17	12	0.8
05000669005	40	48	11	27	20	31.5	32	12	24	4	22	14	1
05000669006	40	60	11	27	20	31.5	32	12	24	4	22	14	1

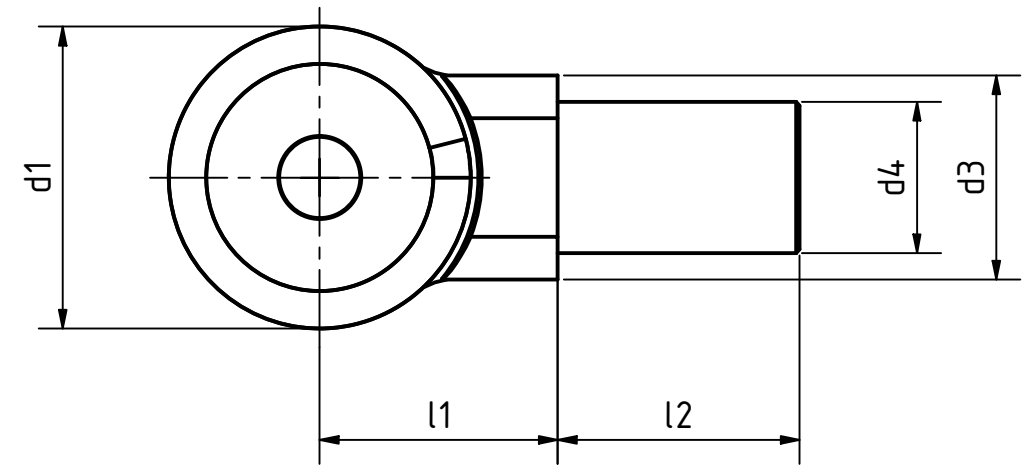
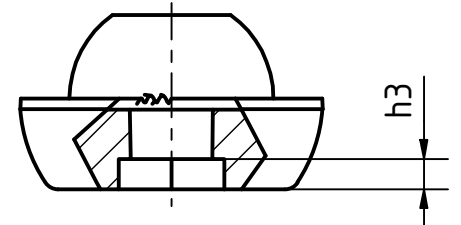
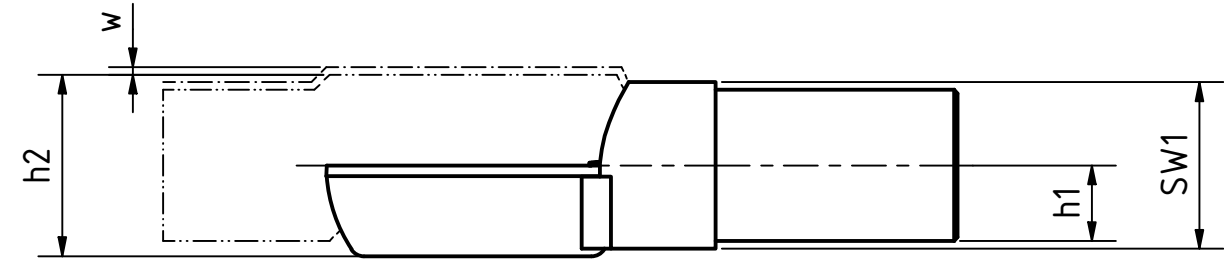
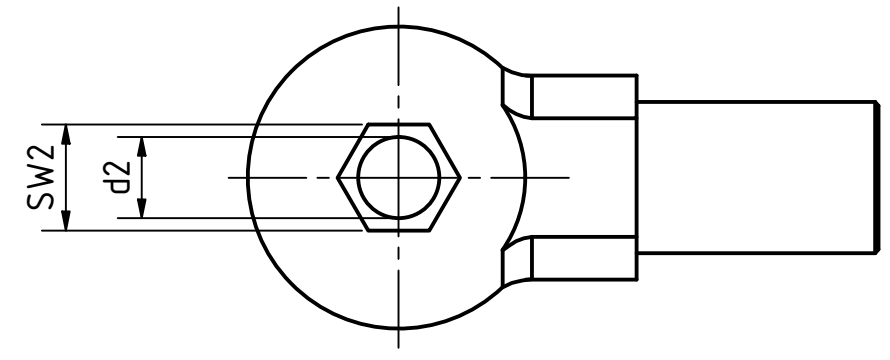

Edelstahlfeinguss 1.4308, nichtrostend, matt gestrahlt

				tolerance DIN2768-mk	
Gezeichnet		Datum		Name	
26.01.2021		Dennis Bruder		Edelstahlrastkopf, Zapfen unbearbeitet	
Kontroll					
Norm					
REVISIONSVERLAUF				05000669000	
Rev.	Änderungstext	Änderungsdatum	Änderungsstamm	Gen.	1
	Erstfreigabe			PJ	A3
weight -				scale 1:1	