

Artikel-Nr. SToxxparts	d1 mm	l1 mm	b mm	d2 mm	d3 mm	d4 mm	l2 mm	l3 mm	l4 mm	l5 (Rastweg) mm	Federdruck (Anfang) N	Federdruck (Ende) N	Axiale Belastbarkeit N
05000764001	6	14	18	10	25	22	45	1.5	5.5	6	9	25	400
05000764002	6	6	18	10	25	22	37	1.5	5.5	6	9	25	400
05000764003	8	18	20	12	31	25	54	2	6.5	8	13	26	500
05000764004	8	8	20	12	31	25	44	2	6.5	8	13	26	500

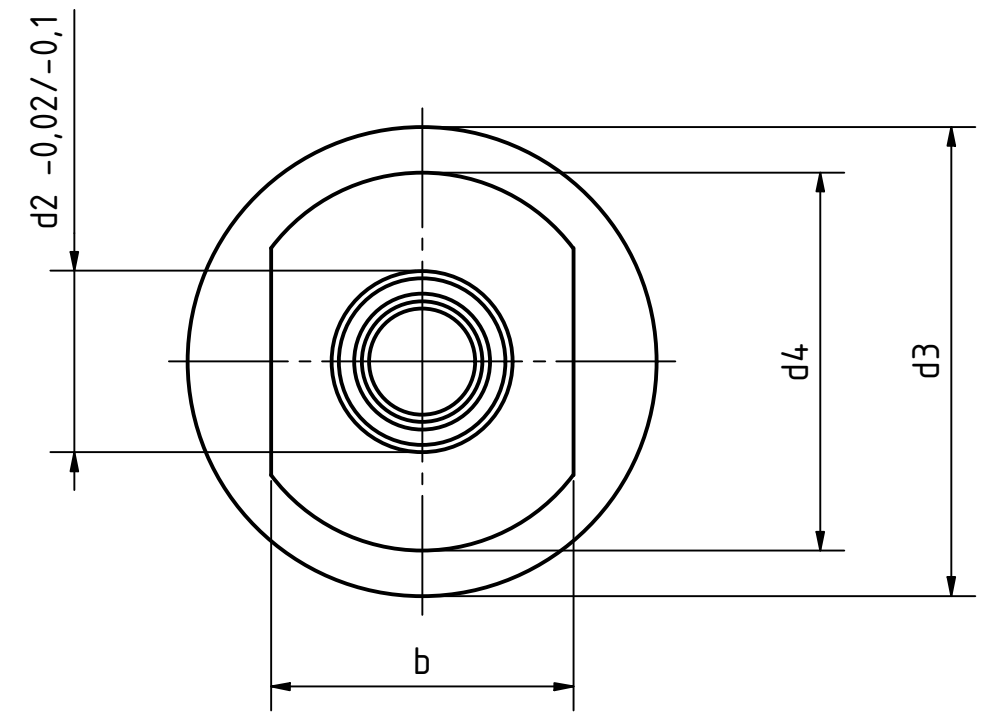
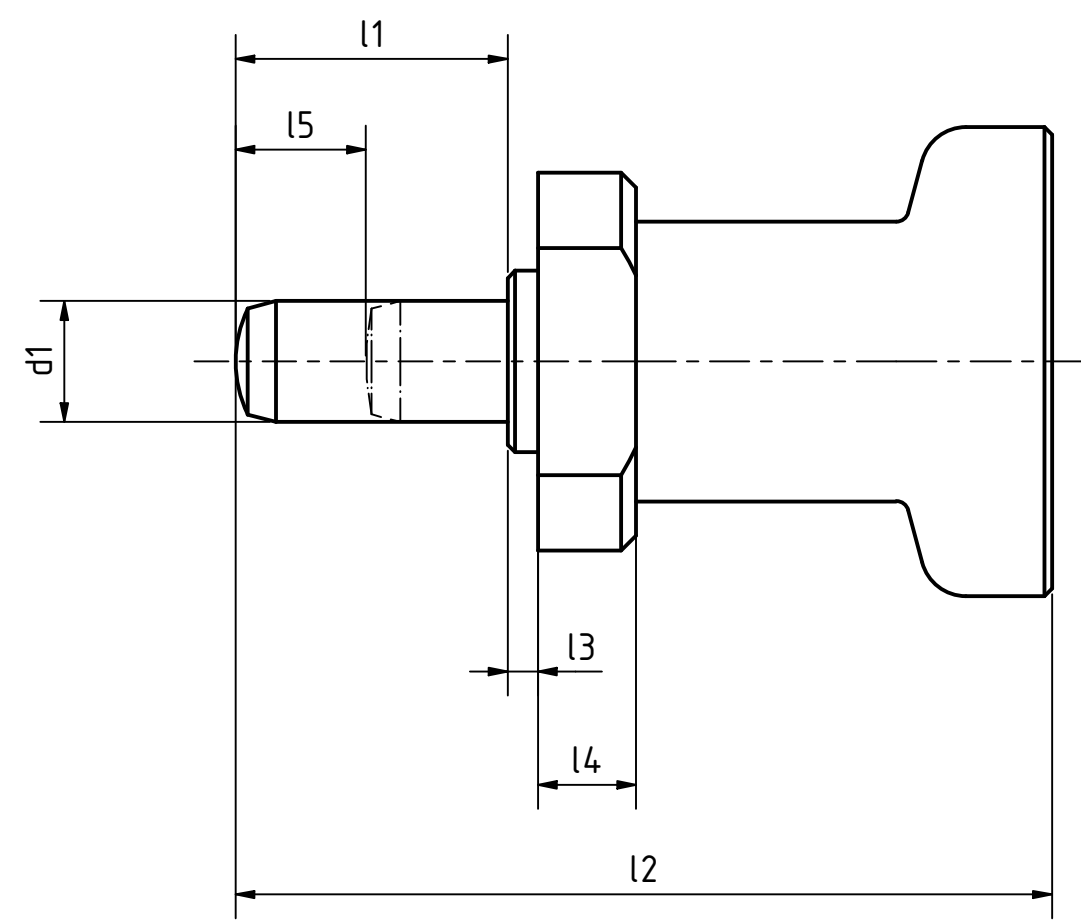
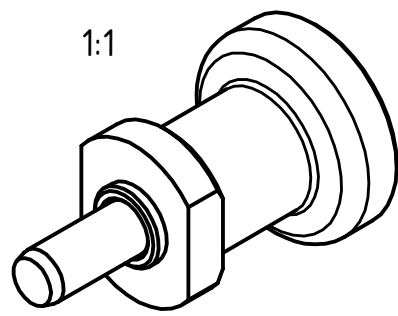

Stahlausführung brüniert, Raststift gehärtet
 Kunststoff Thermoplastknopf (Polyamid PA), schwarz, matt, nicht demontierbar

STOXX parts		tolerance DIN2768-mk	
...der Normteiler			
	Datum	Name	
Gezeichnet	25.02.2021	Dennis Bruder	
Kontroll			
Norm			
		Rastbolzen zum Anschweißen, mit Rastsperr	
		05000764000	
		1	
		A3	
Status	Änderungen	Datum	Name
		weight -	
		scale 2:1	

REVISIONSVERLAUF			
Rev.	Änderungstext	Änderungsdatum	Änderungsstamm
	Erstfreigabe		PJ

