

Artikel-Nr. SToxxparts	d1 mm	z (Zähneanzahl)	d2 mm	d3 mm	d4 mm	h1 mm	h2 mm	m mm	SW mm	t mm	w (min. Ausrastweg) mm
05000707001	35	24	M8	3	12	12	1.7	26	17	2.5	2.5
05000707002	35	36	M8	3	12	12	1.7	26	17	2.5	2.5
05000707003	55	24	M10	4	16	17	2.8	42	22	3	4
05000707004	55	36	M10	4	16	17	2.8	42	22	3	4
05000707005	75	24	M12	5	20	22	4.7	60	27	4	5
05000707006	75	36	M12	5	20	22	4.7	60	27	4	5

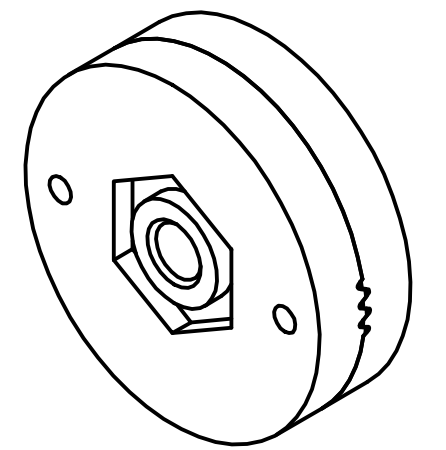
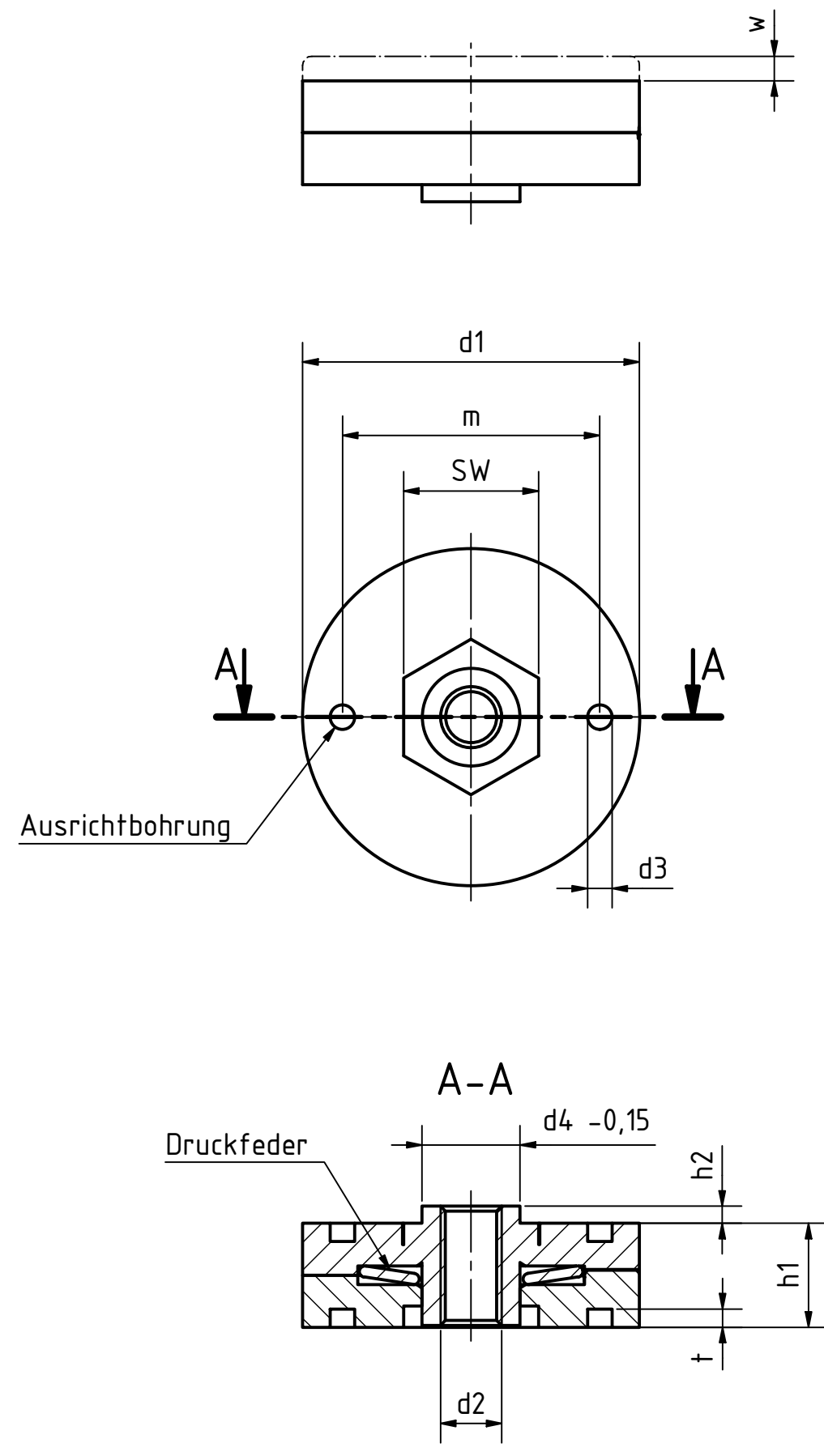

Edelstahl Druckfeder 1.4310, nichtrostend
 Edelstahl Gewindebuchse 1.4301, nichtrostend
 Edelstahl- Feingussausführung 1.4308, nichtrostend

				tolerance DIN2768-mk	
Gezeichnet		Datum		Name	
09.02.2021				Dennis Bruder	
Kontroll		Norm		Edelstahlrastscheibe mit Gewindebuchse und Zentrieransatz, zum Anschweißen	
05000707000				1	
				A3	
weight -				scale 1:1	

REVISION HISTORY				
Rev.	Änderungstext	Änderungsdatum	Änderungsstamm	Gen.