

Artikel-Nr. STOxxparts	Nutennennmaß	Abmessungen												Spannkraft horizontal max.	Gewicht	
		d ₁	a	b	d ₂	h ₁	h ₂	h ₃	h ₄	h ₅	l ₁	l ₂	l ₃			s
	[mm]	[mm]												[KN]	[g]	
17000157001	10	M8	9.6	32	8.4	20	30	8	40	12.6	132	50	32	3	3.5	264
17000157002	12	M12	11.6	48	12.5	38	63	16	62	-	190	72	40	4	7	900
17000157003	14	M12	13.6	48	12.5	38	40	16	62	19.1	190	72	40	4	7	841

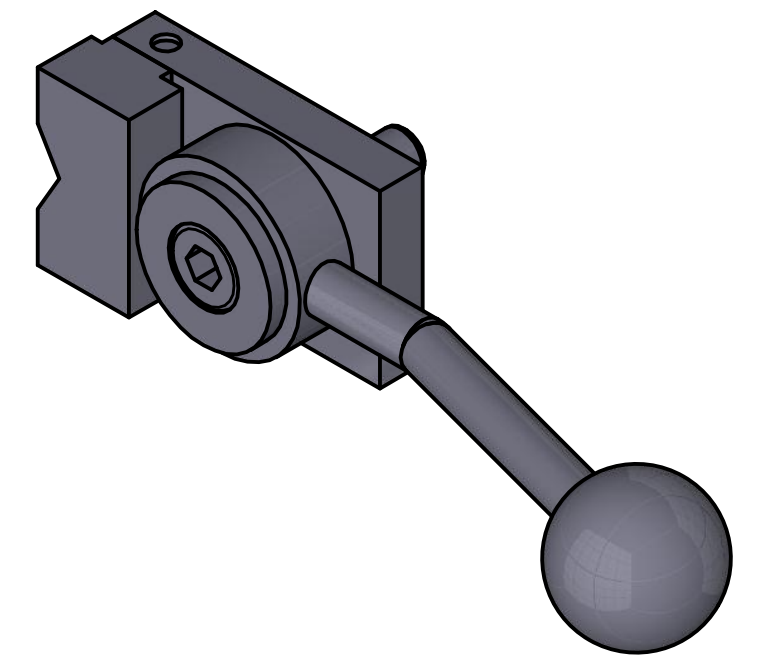
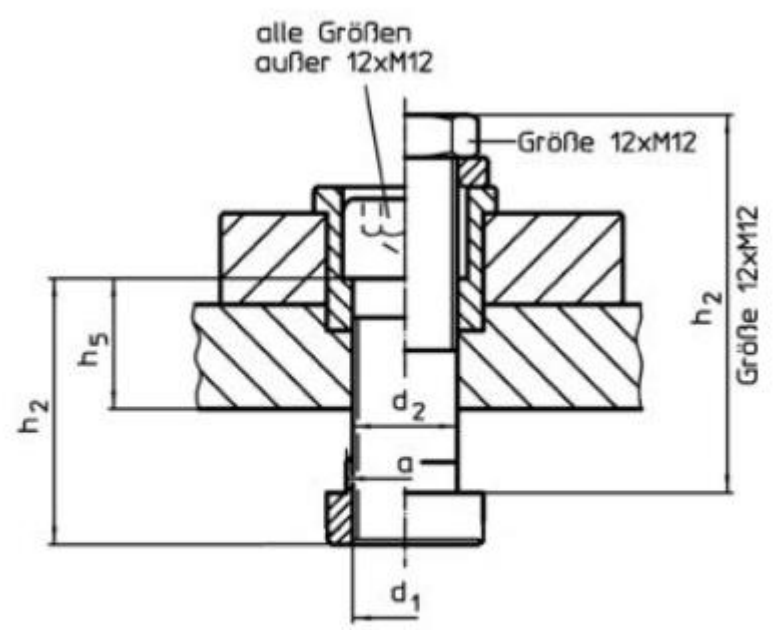
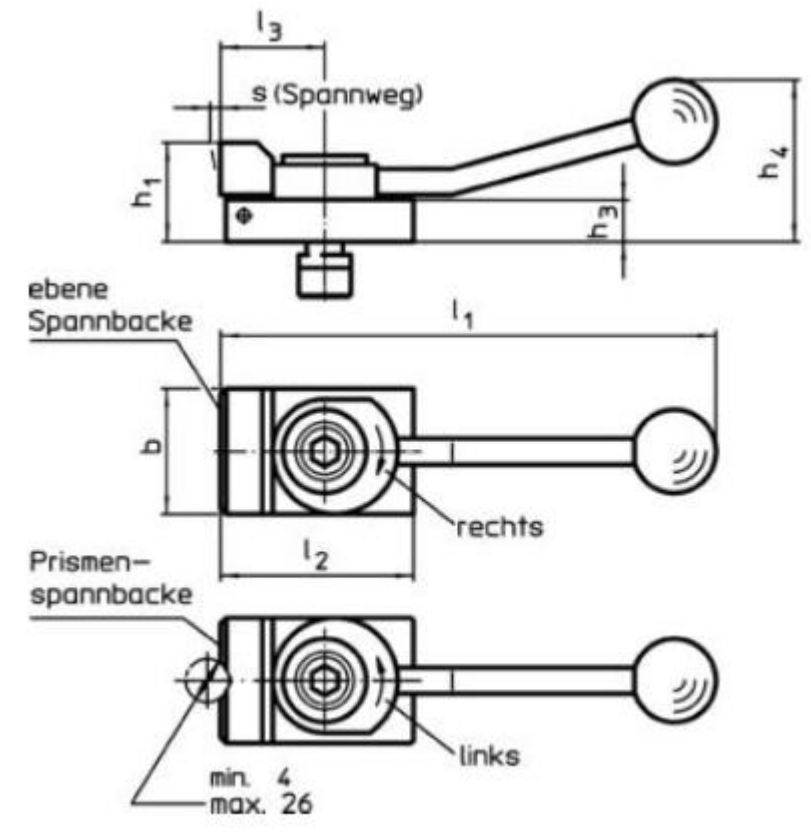

STOxx parts		tolerance DIN2768-mk	
...der Normteiler			
Gezeichnet	Datum	Name	Niederzugspanner, mit gekröpftem Spannhebel, mit Prismen-Spannbacke, Spannrichtung links
Kontrolliert	11.05.2020	Philipp Joos	
Norm	11.05.2020		
17000157000			1
weight -			A3
scale 1:1			

Rev.	Änderungstext	Änderungsdatum	Änderungsstamm	Gen.
6				
5				
4				
3				
2				
1				