

Artikel-Nr. SToxxparts	Abmessungen												d4 Griffstange Ø EH 24350.	Gewicht [g]
	d1	d2 H9	b1 -0.05 -0.15	b2	d3	l	r1	r2	r3	r4	S	t		
	17000235001	24	8	13	11	M6	28	12	13.32	14.64	15.30	3.3	9	8
17000235002	30	10	15	13	M8	32	15	16.65	18.30	19.12	4.1	12	10	100
17000235003	35	12	17	15	M10	36	17.5	19.42	21.34	22.31	4.8	15	12	150

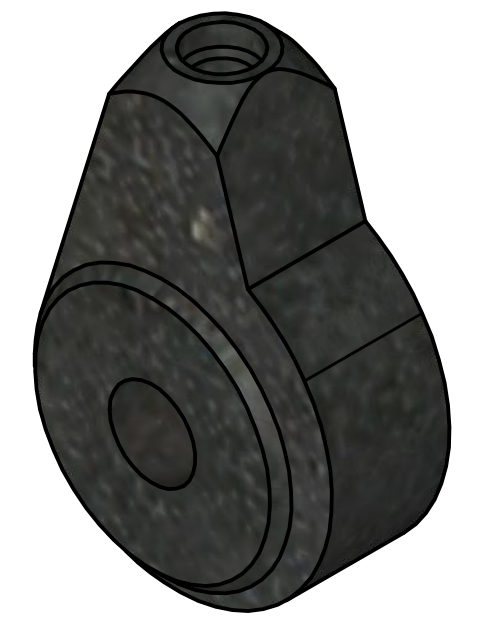
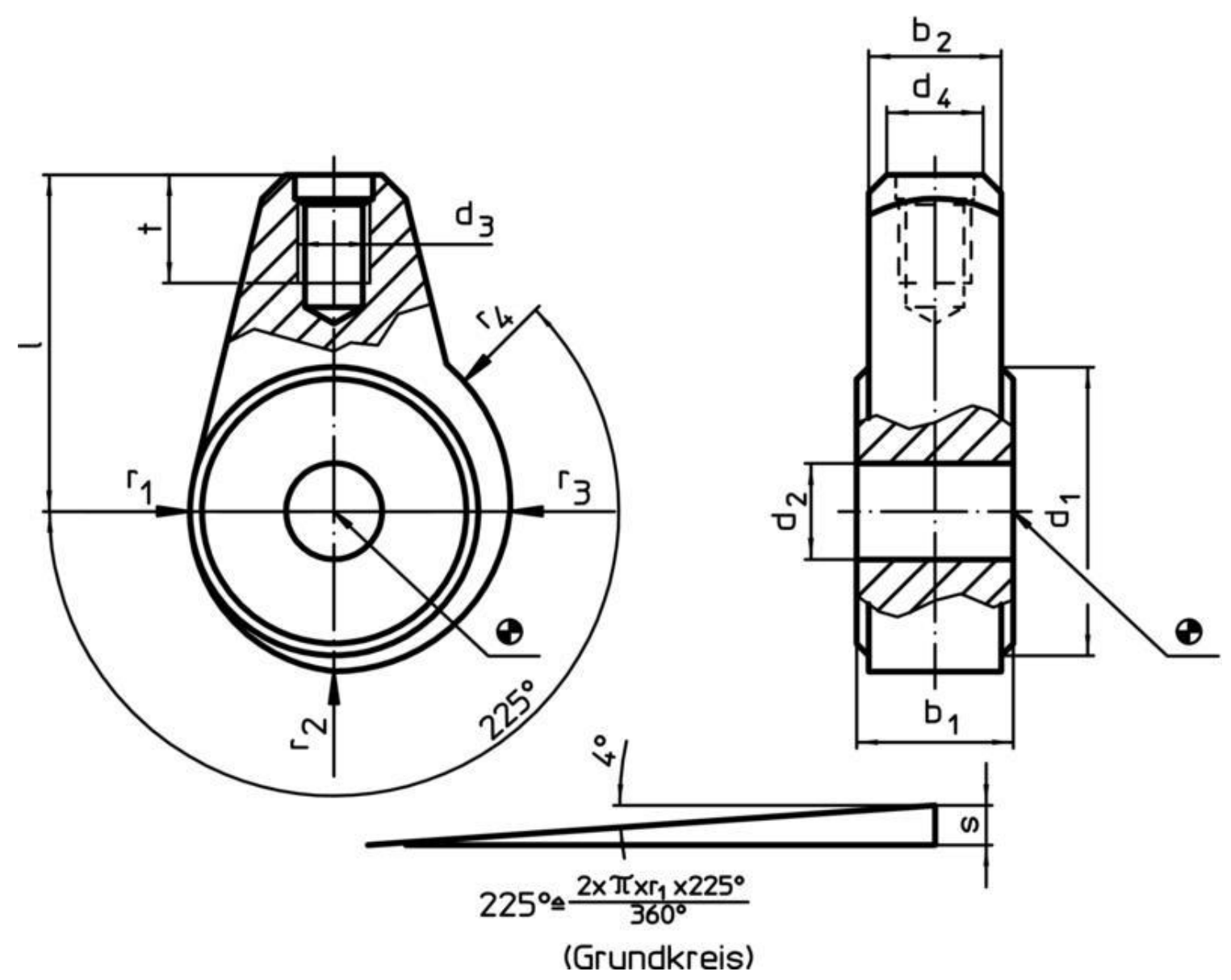

SToxx parts		tolerance DIN2768-mk	
...der Normteiler			
Gezeichnet	Datum	Name	Exzentrerspannmodul, mit Wellenaufnahme
Kontrolliert	18.05.2020	Philipp Joos	
Norm	18.05.2020		
Erstfreigabe		17000235000	
Rev.	Änderungstext	Änderungsdatum	1
		Änderungsstamm	A3
		Gen.	weight N/A
			scale 1:1