

Artikel-Nr. SToxxparts	Variante	d1 (Stift -0.02/-0.06 mm   Bohrung H7)	d2 mm	d3 mm	e ~ mm	l1 mm	l2 mm	l3 mm	l4 mm	SW mm	Federdruck (Anfang) N	Federdruck (Ende) N	Axiale Belastbarkeit N
05000689001	mit Kontermutter	6	M12x1.5	25	19.6	45	6	10	5	17	11	28	400
05000689002	mit Kontermutter	8	M16x1.5	31	21.9	54	8	12	6	19	15	29	500
05000689003	ohne Kontermutter	6	M12x1.5	25	19.6	45	6	10	5	17	11	28	400
05000689004	ohne Kontermutter	8	M16x1.5	31	21.9	54	8	12	6	19	15	29	500

Kunststoffknopf (Polyamid PA), schwarz, matt, nicht demontierbar  
 Stahl brüniert, Raststift gehärtet

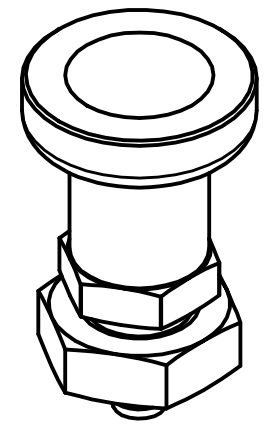
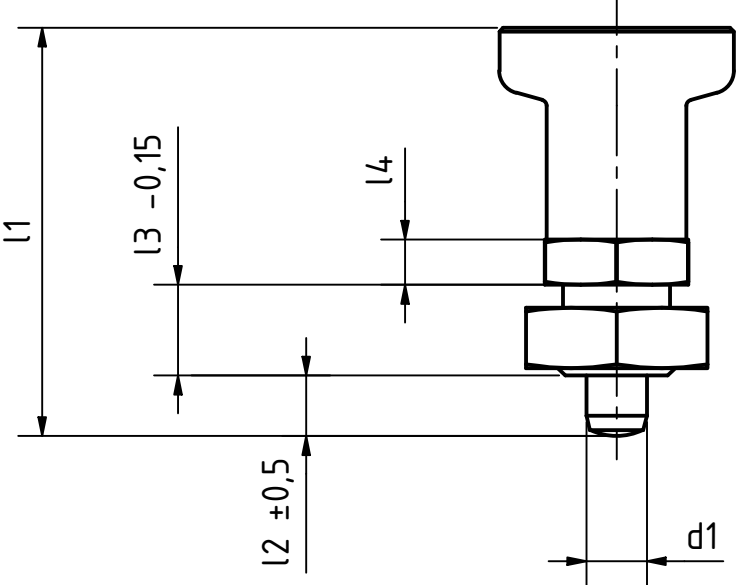
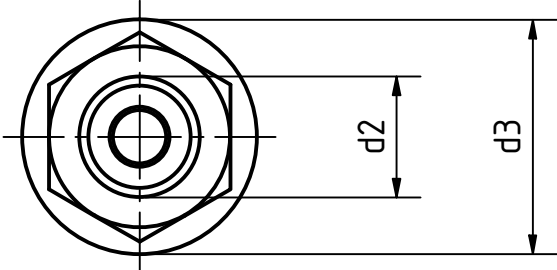
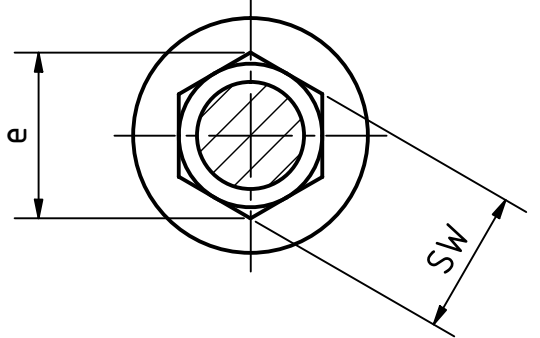

**STOXX**parts  
 ...der Normteiler

Status	Änderungen	Datum	Name

tolerance DIN2768-mk

Stahlrastbolzen mit Kunststoffknopf

05000689000

1  
A3

weight - scale 1:1

REVISION HISTORY

Rev.	Änderungstext	Änderungsdatum	Änderungsstamm	Gen.

