

Artikel-Nr./article-no. SToxxparts	d1 mm	a mm	e mm	h1 mm	k mm
01000011001	M4	4.6	9	6.5	3
01000011002	M4	5.6	10	8	4
01000011003	M5	5.6	10	8	4
01000011004	M5	7.6	13	10	6
01000011005	M6	7.6	13	10	6
01000011006	M5	9.6	15	12	6
01000011007	M6	9.6	15	12	6
01000011008	M8	9.6	15	12	6
01000011009	M6	11.6	18	14	7
01000011010	M8	11.6	18	14	7
01000011011	M10	11.6	18	14	7
01000011012	M8	13.6	22	16	8
01000011013	M10	13.6	22	16	8
01000011014	M12	13.6	22	16	8
01000011015	M12	15.6	25	18	9
01000011016	M14	15.6	25	18	9
01000011017	M12	17.6	28	20	10
01000011018	M14	17.6	28	20	10
01000011019	M16	17.6	28	20	10
01000011020	M16	19.6	32	24	12
01000011021	M18	19.6	32	24	12
01000011022	M20	21.6	35	28	14
01000011023	M20	23.6	40	32	16
01000011024	M22	23.6	40	32	16
01000011025	M24	27.6	44	36	18
01000011026	M30	35.5	54	44	22

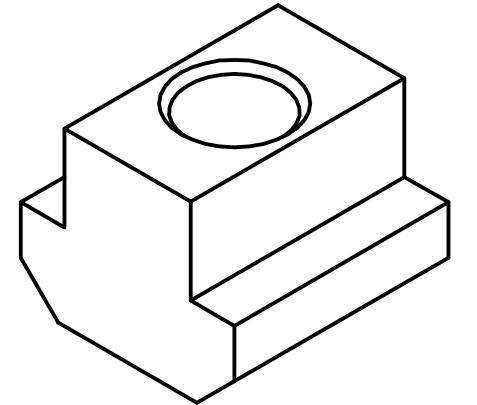

Stahl vergütet (Güte 10)
Steel quenched and tempered (grade 10)

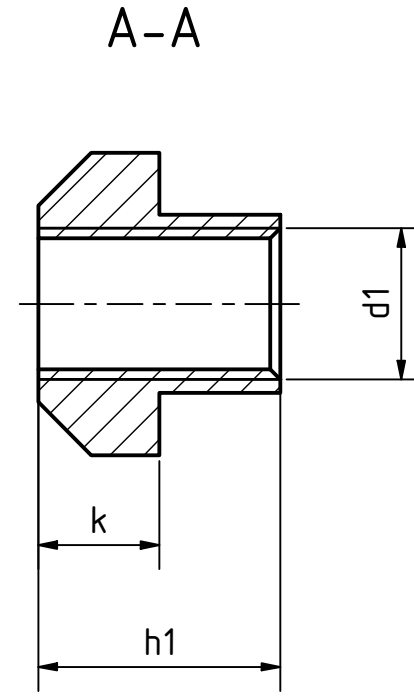
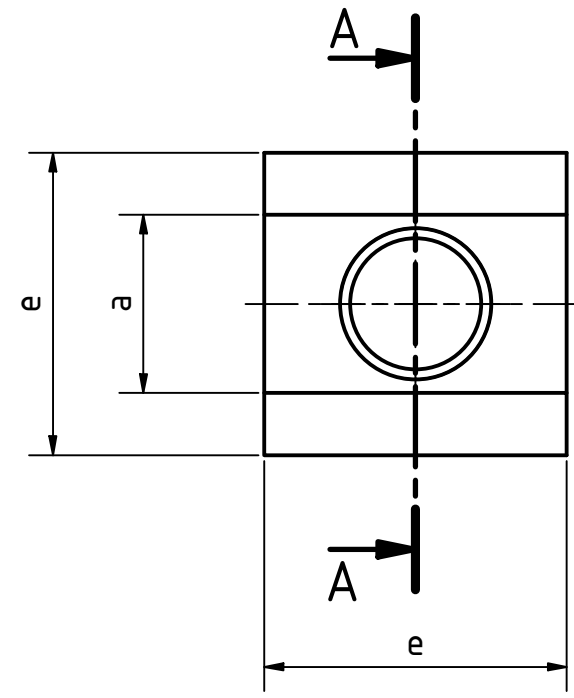

				tolerance DIN2768-mk	
				Mutter für T-Nuten DIN 508	
				01000011000	
				1	
				A3	
				weight -	
				scale 1:1	

REVISIONSVERLAUF

Rev.	Änderungstext	Änderungsdatum	Änderungsstamm	Gen.
	Erstfreigabe			PJ

Status	Änderungen	Datum	Name