

Artikel-Nr. SToxxparts	d1 mm	SR mm	d3 mm	l1 mm	l2 mm	l3 mm	w (Federweg) mm	SW mm	Federdruck (Anfang) N	Federdruck (Ende) N
05000636001	M10	3	16	17	6	-	2	5	24	45
05000636002	M12	4	18	19	7	-	2.5	6	26	49
05000636003	M4	1.25	6	9	3	7.5	0.8	2	8	14
05000636004	M5	1.5	8	10	4	8.2	0.9	2.5	8	14
05000636005	M6	1.75	10	10	5	-	1	3	11	18
05000636006	M8	2.25	13	12.5	5.5	-	1.5	4	18	31

Größe M6 bis M12

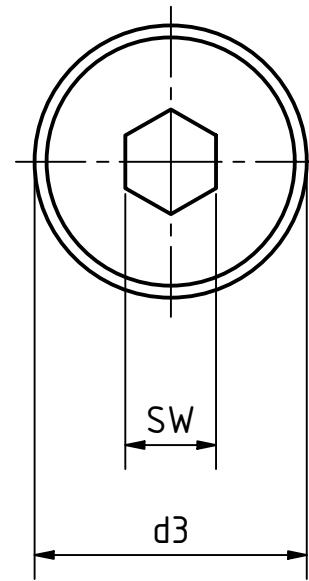

Größe M4 und M5

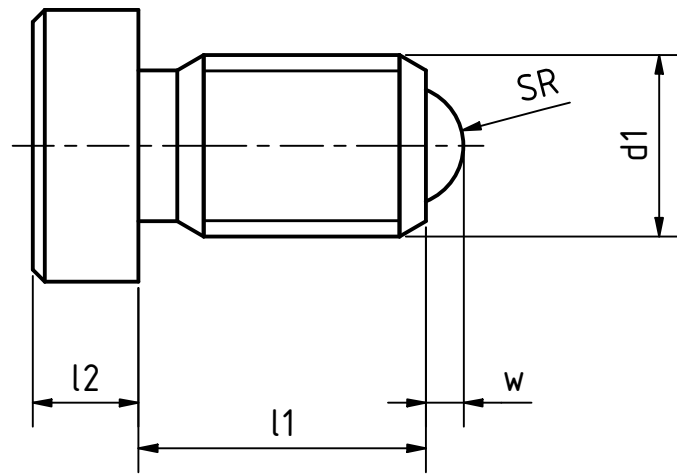
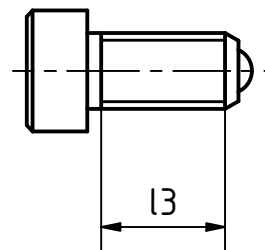

Edelstahlausführung, nichtrostend 1.4305  
Edelstahlkugel gehärtet, nichtrostend 1.3541

		tolerance DIN2768-mk	
		Datum	Name
		Gezeichnet	15.01.2021 Dennis Bruder
		Kontroll	
		Norm	
			Federndes Edelstahldruckstück mit Kugel, Bund und Innensechskant
			05000636000
			1 A3
		weight -	scale 2:1

REVISIONSVERLAUF

Rev.	Änderungstext	Änderungsdatum	Änderungsstamm	Gen.
	Erstfreigabe			PJ

Status	Änderungen	Datum	Name