

Royer Labs

Model R-121

Mono Ribbon Velocity Microphone



Operation Instructions Manual
& User Guide

Made in U.S.A.

TABLE OF CONTENTS

Model R-121 Ribbon Microphone

Revised A

<i>Introduction</i>	3
<i>Description</i>	3
<i>Applications</i>	3
<i>Ribbons in the Digital World</i>	4
<i>User Guide</i>	4
<i>Using the R-121 Ribbon Microphone</i>	4
<i>Amplification Considerations</i>	5
<i>Equalization & Ribbon Microphones</i>	6
<i>Hum, Noise & Mic Orientation</i>	7
<i>The Sweet Spot</i>	7
<i>Finding and Working with the Sweet Spot</i>	7
<i>Other Types of Microphones</i>	8
<i>Proximity Effect and Working Distance</i>	8
<i>The Sound That Is “More Real than Real”</i>	8
<i>Microphone Techniques</i>	10
<i>General Tips for Using the Royer R-121</i>	10
<i>Recording Loud or Plosive Sounds</i>	11
<i>Stereophonic Microphone Techniques</i>	13
<i>Classic Blumlein Technique</i>	13
<i>Mid-Side (M-S) Technique</i>	13
<i>Specialized Recording Techniques</i>	15
<i>Recording on the back side of the R-121</i>	15
<i>Care & Maintenance</i>	16
<i>Features</i>	17
<i>Electrical Specifications</i>	17
<i>Mechanical Specifications</i>	18
<i>Polar Pattern</i>	18
<i>Frequency Response</i>	18
<i>Warranty</i>	19

Introduction

Congratulations on your purchase of a Royer Labs model R-121 ribbon microphone. The R-121 is a handcrafted precision instrument capable of delivering superior sound quality and exceptional performance.

This operator's manual describes the R-121, its function and method of use. It also describes the care and maintenance required to ensure proper operation and long service life. The user guide section of this manual offers practical information that is designed to maximize the performance capabilities of this microphone.

Royer Labs products are manufactured to the highest industrial standards using only the finest materials obtainable. Your model R-121 went through extensive quality control checks before leaving the factory. Normal care is all that is required to assure a lifetime of trouble-free service.

Please read the manual thoroughly in order to become familiar with all of the R-121's capabilities. It will assist you in making the most of your microphone's superior acoustic properties. This owner's manual is a handy reference guide and we suggest you refer to it whenever questions arise on the use and care of your R-121 ribbon microphone.

Description

The R-121 is a compact bi-directional (figure-eight) velocity type ribbon microphone designed for professional applications. The figure-eight pick-up pattern allows the R-121 to be addressed from either side with equal sensitivity. The in-phase signal is achieved when the microphone is addressed from the front, indicated by the "ROYER" logo.

The R-121 is reasonably tolerant to shock and vibration, and performance is unaffected by changes in temperature or humidity. However, ribbon microphones are somewhat more sensitive to direct blasts of air, and the R-121 is no exception to this rule. Discretionary use of a windscreen or pop screen, such as the Royer PS-101, WS58 or equivalent, is highly recommended for close-miking vocalists or certain types of percussion and wind instruments.

Applications

The Royer Labs model R-121 is a versatile microphone and is ideally suited for many critical recording applications. Its smooth frequency response characteristics and ability to capture detail make it a fine choice for many instruments, as well as for general broadcast applications. Its gentle low-frequency proximity effect makes it especially useful for announcers and vocalists. Female vocalists often benefit from the R-121's ability to capture high frequencies without distortion or edginess. Orchestral instruments are captured in a natural-sounding way and free from microphone-induced hype. The R-121 has exceptionally smooth high frequency

characteristics. Phase-related distortion and irregular frequency peaks are conspicuously absent. Electric guitar amplifiers sound big and natural, without unnatural coloration, when reproduced with the R-121. The R-121 ribbon microphone is an ideal choice for strings, woodwinds, percussion, organ and amplified instruments. Acoustic pianos can be captured accurately without the comb filtering effects associated with condenser microphones.

Ribbons in the Digital World

Digital recordings benefit greatly from the properties inherent in ribbon microphones. Since A to D converters cannot distinguish between the sound source being recorded and the complex distortion components often associated with condenser microphones, they sometimes have difficulty tracking the signal, resulting in ringing and edgy-sounding tracks. With ribbon microphones, ringing is almost nonexistent due to the ribbon's lack of distortion artifacts and high frequency peaks. A to D converters have less difficulty tracking the ribbon-generated signal, resulting in very smooth digital recordings free of microphone-related edginess.

User Guide

Using the R-121 Ribbon Microphone

There are a few important facts about ribbon microphones that are key in understanding how to use them intelligently.

1. The R-121 is a *side address*, bi-directional microphone and its rejection in the dead areas is very strong. Due to this directionality, the R-121 should be placed at 1.3 times the distance normally used with omni-directional microphones, or about the same distance used for cardioid microphones. This method is used to achieve the same ratio of direct to reflected sound.
2. In the horizontal plane, the R-121 does not discriminate against the highs off axis; nor does it boost highs on axis. Therefore, several instruments or vocalists can be placed in front of the microphone without favoring the performer in the center of the group.

Several performers can be grouped at both the front and back of the microphone, with one proviso: since the outputs are out of phase at the front and back of the microphone, cancellation can result if, for example, two tenors are placed at opposite sides at equal distances and they are singing in unison, so listen to the feed before committing to it.

3. When using the R-121 to record loud signal sources, placing the microphone slightly off axis to the signal source (either horizontally or vertically) minimizes the effect of high pressure sound levels displacing and possibly damaging the ribbon element.
4. The R-121 requires no power supply and is safe to use on consoles with phantom microphone powering, provided that the cabling is wired properly. It should be noted that not

all ribbon microphones are compatible with phantom-powered systems, so check the manufacturer's recommendations before using other ribbon microphones. It should also be noted that faulty or improperly wired cables could cause problems with your R-121. Do not patch an R-121 through the mic tie lines of a patch bay if phantom power is enabled on any of your mic pre's, as this will give the ribbon element a brief but damaging phantom power jolt.

5. Never attempt to test the R-121 or any ribbon microphone with an ohmmeter. A blown ribbon could result.
6. Always provide adequate protection for your R-121, or any ribbon microphone. If the microphone is to remain set up on a stand when not in use, place a mic sock (supplied with every Royer microphone) over it until it is to be used. Do not carry the microphone around without placing a mic sock over it. Failure to follow this common sense practice may yield a stretched ribbon and compromised performance.
7. Do not allow the microphone to be dropped on hard surfaces such as floors or tables - depending on how the mic falls, you could stretch the ribbon. The microphone would likely continue to operate, but performance could be compromised and re-ribboning the microphone would be necessary to restore normal operation.

Amplification Considerations

The performance of any non-active ribbon microphone is directly affected by the microphone preamplifier it is paired with. With so many mic preamps on the market, how do you select one that gives the best possible performance with a ribbon microphone? Additionally, what kind of performance can you expect from the preamplifiers built into your mixing desk? While most preamplifiers will handle ribbon microphones well in most recording situations, some preamps that work perfectly well with condenser or dynamic mics may prove to be poor performers with ribbons.

To begin, we must understand the fundamental differences between ribbon microphones and other popular types, namely condenser and moving coil dynamics. A ribbon microphone is actually a dynamic microphone that uses a corrugated, extremely low mass ribbon element, rather than a coil/diaphragm assembly. For this writing, any mention of dynamic microphones will relate to moving coil dynamics.

All condenser microphones have a built-in preamplifier called a head amp, and therefore put out a hefty signal. Because the signal is buffered through the head amp, the output impedance is rather low and less affected by the input impedance of the microphone preamp. Most dynamic (moving coil) microphones generate a healthy enough electrical current to work well with a variety of preamps, and their limited frequency response characteristics make mic loading less of a concern.

Ribbon microphones generate a highly accurate signal, but the average ribbon mic generates approximately 20dB less output than condenser microphones. Remember, the ribbon transducer does not have the benefit of a condenser mic's built-in "head amp," so a non-powered ribbon microphone relies solely on the microphone preamp for all its gain!

The so-called ideal preamplifier is the proverbial "straight wire with gain." This may be considered the technological ideal and does not include coloration as a desirable feature. However, coloration is often desirable and has given rise to the popularity of certain preamps and even preamp stages in mixing desks. Neve preamps and the famous Trident A Range mixing console are highly praised for their classic sound.

So what pre's should we use with our beloved ribbon microphones?

The features that translate into top performance for a ribbon microphone are the following:

1. High gain. A ribbon microphone works best with preamplifiers that have at least 60-70dB of clean gain.
2. Low noise is a must! With the amount of gain required for efficient operation of a ribbon microphone, the noise characteristics of the preamp play a pivotal role in overall performance of the captured acoustic event.
3. Load characteristics: A suitable preamplifier should have input characteristics that impose the least amount of loading on the ribbon element. In other words, the input impedance should be high enough that its effect on the performance of the mic is negligible. A good rule of thumb is to have a preamplifier with input impedance at least *five times* the impedance of the microphone.

For example, if the mic is rated at 300 Ohms (as the R-121 is), the preamp should have an input impedance of at least 1500 Ohms. If the impedance of the preamp is too low, the microphone will lose low end, body and sensitivity.

4. Transparency: A good preamp should sound natural, with no edginess. Tube preamps sound warm, yet wonderfully transparent. Transformer coupled preamps sound punchy. When recording with condenser or dynamic microphones, engineers often choose mic preamps that help "warm up the mic," but warming the signal up is not as important a consideration with ribbon mics because they are by nature warm and realistic sounding. At this point personal taste should prevail over anything else.

In conclusion, try to find the best preamp you can afford that has good gain characteristics and low noise. Coloration is optional.

Equalization & Ribbon Microphones

One of the great strengths of ribbon microphones is how well they take EQ. Even with substantial amounts of equalization, ribbons retain their natural, real quality. For example, when a lead vocal is being performed on an R-121, you can actually boost upper-end frequencies to the point where the R-121 emulates the performance curve of a condenser mic with excellent results.

This is not to say that a ribbon microphone can substitute for a quality condenser mic in all cases, but the EQ friendliness inherent in ribbon microphones does allow for an enormous amount of flexibility.

Ribbon mics take EQ so well because of their inherent low self-noise, unusually smooth frequency response characteristics, and freedom from off-axis coloration. Dialing in high amounts of equalization on condenser or dynamic microphones also brings up equal amounts of the microphone's distortion products and noise; garbage that contributes to an unnatural, unpleasant sound. Because distortion and self-noise are almost nonexistent in ribbon microphones, high levels of EQ can be used without adding harshness or excessive noise.

Hum, Noise & Mic Orientation

All dynamic microphones, including ribbons, are electromagnetic devices and are, to some degree, susceptible to picking up stray alternating magnetic fields. Power transformers (such as those found in guitar amplifiers) and alternating current motors are the most likely sources of radiated noise. Building wiring and electrical utility transformers are other likely sources. A well-designed microphone provides shielding to minimize the effects of stray magnetic radiation, but complete isolation is impossible and the result can be hum or buzz. Ribbon microphones can potentially manifest this condition to a greater degree because of their higher gain requirements. Vintage ribbon microphones often have poor shielding and the problem can be worse. The cure for this problem is to identify the source of the noise and move the microphone away from it. Another trick is to alter the orientation of the microphone in such a way that the noise is cancelled out. If you ever experience this situation while in the studio, try rotating the microphone to identify the "null" point, then reposition the mic and the sound source. This is much like having a guitar player with single coil pickups turn around until amplifier hum disappears.

The Sweet Spot

Finding and Working with the Sweet Spot

Good engineers know the benefits of finding and working with the "sweet spot." The sweet spot will be defined as the optimum placement (working distance and angular position) of any microphone relative to the sound source.

Each microphone has its own sweet spot whether it is a ribbon, dynamic or condenser type. The sweet spot will vary with the type of sound source and its volume intensity, the polar pattern of the microphone and how consistent it is with frequency, and the acoustic environment.

Being in the sweet spot means the microphone and the sound source are in a harmony of sorts; the acoustic information is exciting the microphone in such a fashion that the resulting reproduction is very desirable, usually without the need of additional equalization or electronic manipulation.

There are only general rules as to where the sweet spot may be found for any given microphone, and usually experimentation reveals it. The sweet spot can be extremely variable since it depends on the quirks of a given microphone and a given room. Once the sweet spot is discovered, this placement can become a rule of thumb starting point for future microphone placement with similar sound sources. Remember this: If it sounds good, it's probably right. If it doesn't, move the microphone. It's often more effective to reposition the microphone than to start fiddling with knobs. Knob twisting can affect headroom and phase coherency and add unwanted noise.

The following is a list of variables that account for "sweet spot" effect:

1. Frequency response variations due to proximity effect.
2. Frequency response variation due to treble losses as a result of absorption and "narrowing" of the pattern at high frequencies, causing weakening of highs as the microphone is moved away from the sound source.
3. Variation in ratio of direct to reverberant sound.
4. Tendency of a microphone to favor the nearest sound source due to a combination of these items, plus the influence of inverse square law. Inverse square law states that for each halving of source-to-microphone distance, the sound pressure level *quadruples*.

Other Types of Microphones

For the same ratio of direct to reverberant sound, omni-directional microphones must be closer to the sound source than cardioid or bi-directional microphones. Microphones should generally face the sound source head-on or treble losses due to phase cancellation can result. The exception here is for large diaphragm condenser microphones, which often give the flattest response at an angle of about 10-20 degrees (off axis), where phase loss and diffraction effect offset each other somewhat.

Proximity Effect and Working Distance ***The Sound That Is "More Real than Real"***

Ribbon microphones have long been renowned for rich bass. This effect is largely due to the fact that ribbon microphones generally have excellent bass response to begin with, and at the same time exhibit an effect known as *proximity effect* or *bass tip-up*.

As illustrated in the following graph, a typical bi-directional ribbon microphone will have a flat frequency response at a distance of about six feet from the microphone, but at shorter distances the bass response is boosted; the effect becomes increasingly pronounced as the distance between the microphone and the sound source is reduced.

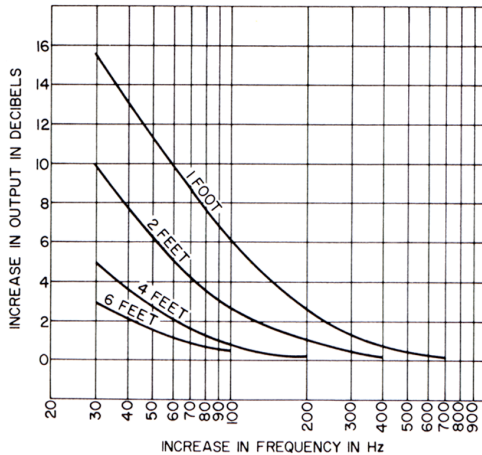

Typical relationship of microphone distance to frequency response for ribbon-velocity bidirectional microphone.

This bass-boosting characteristic can become quite intense and, if desired, can be corrected by equalization. However, for a multiple microphone setup, the pronounced bass boosting (due to proximity effect) can be turned to an advantage. If an instrument, such as a trumpet, is extremely close-miked and the bass is cut to restore flat response, unwanted low-frequency sounds are cut back by upwards of 20dB compared to an unequalized microphone with a flat response. This discrimination is *independent* of the microphone's polar response.

Another area where proximity effect can be turned to an advantage is to make things sound "more real than real." For example, many voices and certain musical instruments produce fundamental frequencies within the bass range (below 150Hz or so) but the fundamentals are weak. If a microphone which has no proximity effect and a rising high frequency response is used on an upright piano, or on a person with a thin, weak voice, the recorded sound is likely to sound even thinner than it was in real life. In contrast, using a microphone with strong proximity effect on such sound sources can deliver a "better than real" sound since the boosted bass response will compensate for the weak fundamentals in the sound source. Since the fundamentals are present, but weakened, boosting them by several dB will sound natural, even though the sound has been sweetened.

Radio and television announcers have long relied on proximity effect to give a full, rich, authoritative quality to their voices. By knowing how to work with the proximity effect, the engineer can get several useful effects without resorting to a box.

Microphone Techniques

General Tips for Using the Royer R-121

The following are good basic starting places for recording with the R-121. These positions are known to produce good results, but experimentation is the key to getting the most out of your recordings! Photographs of many of the following techniques can be found at www.royerlabs.com.

Brass Instruments and R-121s go together very well. Mic the instrument from a distance of a couple of feet, and increase the working distance a little if several instruments are being used.

Reed Instruments sound full and never edgy when captured with an R-121. Normal working distances are about a foot or two from the instrument.

Strings sound very sweet and clean when recorded with R-121s. Place the microphone several feet from the instrument. For larger string sections, try placing the microphone slightly above the instrumentalists and angled down; a distance of three or four feet will do the trick nicely.

Pianos sound excellent when recorded with R-121s and are free of phase-related comb filtering. The bass is full and rich while the top remains clean with no clatter. Mic the piano at a distance of one foot to several feet, depending on taste. A more direct, up front sound will be achieved when the microphone is placed closer to the soundboard.

For capturing a piano in stereo, place a pair of R-121s apart, one over the bass strings and the other over the high strings. The farther the mics are from each other, the wider the stereo spread. For a more direct stereo effect, the microphones may be placed in an X-Y pattern a couple of feet from the center of the soundboard.

Amplified Instruments should be miked from a distance of 6-8 inches or more. The smooth undistorted bass response is very useful for electric guitars and particularly electric bass.

Since guitar amplifier speakers are often beamy, experiment with mic placement to find just the right spot. Placing the mic at greater distances from the speaker cabinet adds more room ambience to the mix. You will find that the R-121 does not add undesirable elements to the sound. Basically, what you hear at the amp is what you get in the control room and in your recordings.

Choirs and Orchestras can be picked up well with two R-121s. Place the microphones at a height of ten feet or so and a few feet behind the conductor. The microphones should be spaced apart approximately one foot and angled, one toward the left and one toward the right.

Drums and Percussion instruments sound full-bodied and natural when recorded with a pair of R-121s. For a drum set, placing the microphone(s) at a distance of four to six feet above the kit works very well without making the cymbals sound splattered.

A kick drum should be miked at a distance of at least 18 inches and possibly used in conjunction with a blast filter to prevent excessive ribbon movement. If the front head has a hole cut in it, position the microphone away from the hole to avoid excessive air blasts. An R-121 used as a mono room mic, four to six feet in front of the kit and compressed, will yield a surprisingly large, full drum sound.

For closer miking of a kick drum (10 to 18 inches), the microphone should be leaned forward at a 45-degree angle to protect the ribbon element from excessive plosive forces (*See Example 3*). This microphone position also provides good kick drum isolation because the top of the microphone, which does not pick up sound, is aimed at the rest of drum kit.

Recording Loud or Plosive Sounds

With all ribbon microphones, *wind is the enemy!* Air movement is far more damaging to ribbon microphones than high SPL's. Some sound sources can generate powerful blasts of air that should be avoided. Kick drums and electric guitar and bass amplifiers are typical examples of sound sources that can produce harmful air currents. One way to determine if the air pressure is excessive is to place your hand in front of the sound source (the kick drum, the guitar cab, etc.). If you feel air movement, do not put your ribbon microphone there. A simple technique that can avert damage due to over-stressing the ribbon is as follows: After choosing the optimum placement for the microphone, slightly angle the microphone in such a way that the percussive wave is not directed at the front of the mic "head on." *Often, a slight angular tilt (either vertically or horizontally) is all that is required to prevent harm to the ribbon. (See Example 1)*

1. Example of the Vertical Positioning Technique

Slight off-axis positioning will minimize stressing the ribbon on loud sound sources.

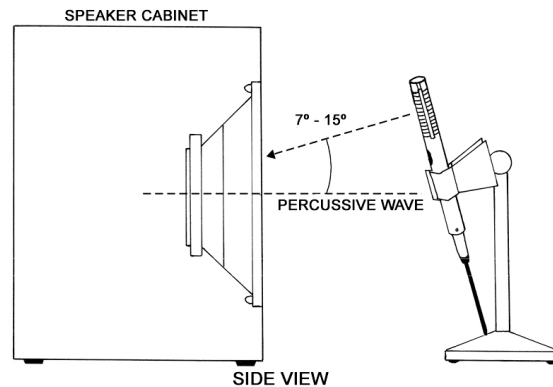

2. Example of Horizontal Positioning Technique

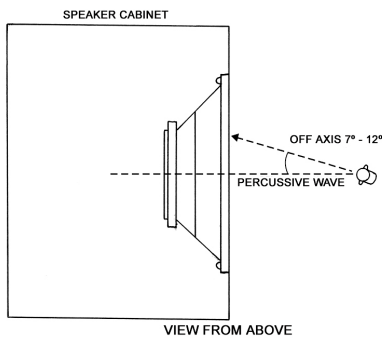

Angling the microphone slightly will minimize stressing the ribbon. Due to the microphone's pickup pattern, sound will not be affected.

3. Side View of Kick Drum Miking Technique

- A) Close miking—angle mic so that pressure wave is off-axis
- B) Standard miking position

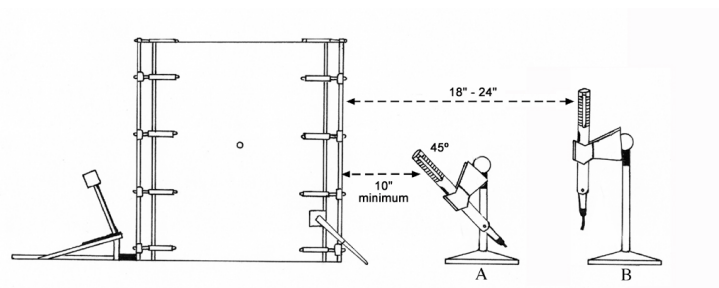

4. Horizontal Positioning Technique

Applied to kick drum—similar to that utilized for other loud or percussive instruments

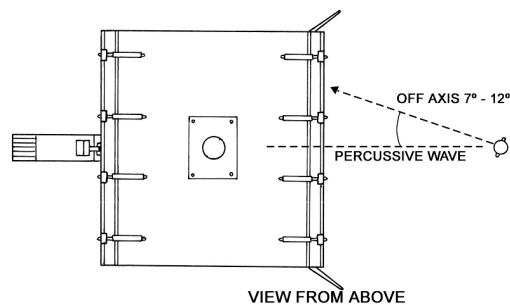

Stereophonic Microphone Techniques

Classic Blumlein Technique

For many years, several coincident microphone setups have been widely used for recording in stereo as naturally as possible.

The “Blumlein” technique, named for A.D. Blumlein of England, involves the use of two figure-eight microphones positioned as in the sketch (*see Figure 1*), so that one faces left and the other right, at an angle of 90 degrees (i.e. each displaced 45 degrees from center).

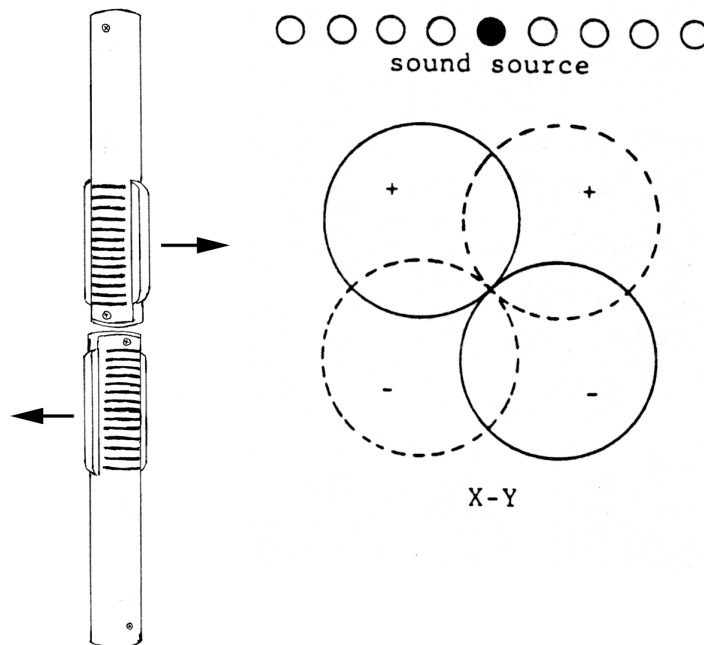

Figure 1
Classic Blumlein or coincident miking technique

Each microphone ultimately feeds one speaker in a stereo system, and due to the directionality of the microphones, the result is a very well defined stereo effect on playback. For classical music, particularly, the reproduction can be very satisfying.

Mid-Side (M-S) Technique

In the early days of stereo radio broadcasting, the mid-side recording technique was developed to allow for 1) simultaneous stereo and mono feeds from the same mic array and 2) electronic manipulation of the width of the stereo image.

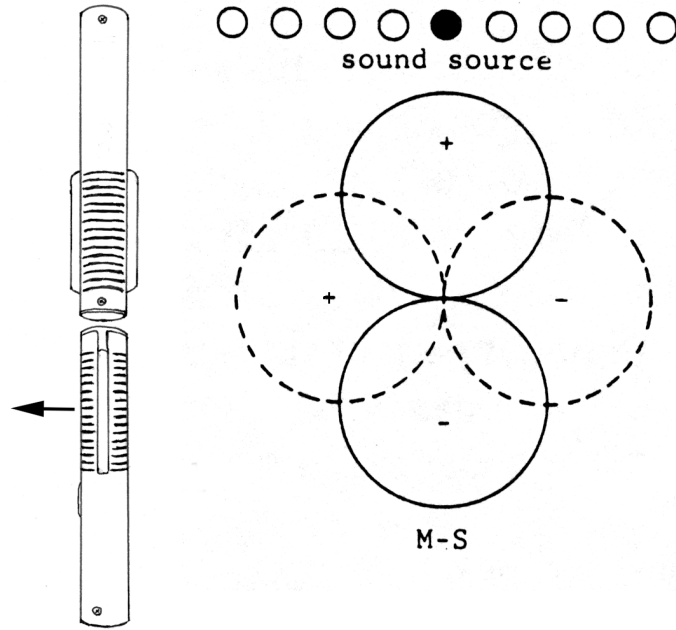
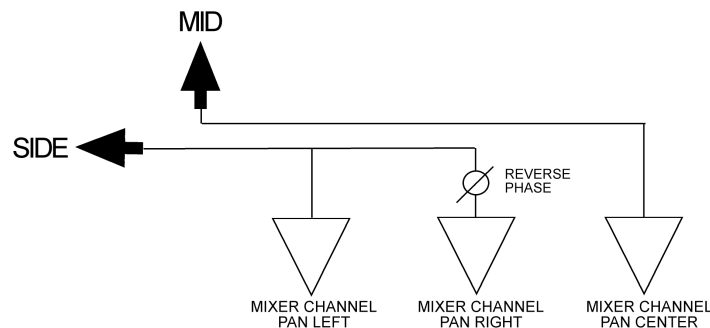

Figure 2 - Typical M-S Miking Technique

In M-S recording, one mic faces sideways, one faces forward as shown in *Figure 2*, and they are connected as shown in *Figure 3*. If the outputs of the two microphones are equal (or made equal using gain controls), the stereo pickup will be similar to that of two microphones placed as a Blumlein X-Y pair, delivering a wide stereo image.

As you reduce the level of the “side” microphone, the width of the stereo image will narrow until, with the side microphone turned all the way down, you have just the “mid” mic panned center for a mono pickup.

If the outputs of the “mid” and “side” microphones are recorded on separate tracks, the electrical connections shown in *Figure 3* can be made at the mixer outputs and the adjustment of the stereo separation can be done during mixdown, rather than during the actual recording.



*Figure 3
Typical M-S connection set-up*

Specialized Recording Techniques

Recording on the back side of the R-121

The R-121 incorporates an “offset ribbon” design that enables it to handle high sound pressure levels such as those produced by loud guitar amplifiers and other instruments. An interesting phenomenon as a result of this offset ribbon construction is that the R-121 records slightly brighter on its back side than on its front (logo) side, when the microphone is three feet or closer to the sound source. This can be extremely useful when a brighter response is desirable, such as when recording acoustic instruments or vocalists.

When recording vocals on either side of an R-121, a quality pop filter (such as the Royer PS-101 metal pop screen) is essential to protect the ribbon element from wind blasts. As with any figure-8 microphone, the front side of the R-121 is in-phase and the back side is out-of-phase. We suggest that you reverse the phase polarity on your microphone preamplifier to achieve in-phase recordings when tracking on the backside of an R-121.

Normal proximity effect (increase of bass), which is prevalent on the R-121 and all ribbon microphones, increases with closeness to the microphone. Vocalists and voice-over talents often take advantage of proximity effect to give an authoritative quality or rich texture to their voice.

Cautionary Note:

It is important to note that the SPL handling capability of the rear side of the R-121 is lower than its front side. The R-121 is rated for 135dB SPL on its front side, but recordings on the rear side should not exceed 115dB SPL. When tracking loud sounds on the front side, the R-121's offset-ribbon design allows ample space for rearward excursions of the ribbon element. However, tracking on the back side causes the ribbon to move forward towards the front side of the microphone, where the internal dampening screen is much closer to the ribbon element. Rear-side recordings of loud, low-frequency sounds, or vocalists with no pop filter, can drive the ribbon into the front dampening screen, creating noise and possibly damaging the ribbon element. Limit back side recording on your R-121 to lower SPL sound sources.

Care & Maintenance

The R-121 is a hand-built precision instrument. All that is required to ensure proper operation of this microphone is to follow some common sense rules.

1. Avoid transducer damage by not exposing the microphone to severe shock or vibration. If the microphone is accidentally dropped, test it to see if damage has occurred before returning it to service. Low output or a dull sound would indicate a damaged ribbon.
2. *Do not expose the microphone to direct blasts of air or strong air currents!* Use a windscreen or suitable blast filter when close miking a vocalist or certain types of wind instruments. Popping does not necessarily damage the ribbon element but may produce unacceptable preamplifier overload and could cause damage to speaker systems.
3. Do not expose the microphone to liquids or caustic smoke.
4. To avoid hum, do not expose the microphone to strong alternating electromagnetic fields, such as the power transformers in amps.
5. Use a soft cloth to clean the microphone body. A small amount of denatured alcohol can be used to remove fingerprints and other stains.
6. Keep metal filings away from the microphone at all times.
7. When not in use, store the microphone in its protective wooden case.
8. Leave disassembly of the microphone to a trained technician. Disassembly of the microphone will void your warranty. There are no user-serviceable parts inside.

Caution!

Keep recorded tapes, spring-wound watches, and personal credit cards using magnetic coding away from the microphone to prevent possible damage caused by the transducer's powerful magnets.

Features

- Very high overload characteristics – maximum SPL greater than 135dB
- No internal active electronics to overload or produce distortion up to maximum SPL rating
- Extremely low residual noise
- Ribbon element is unaffected by heat or humidity
- Absence of high frequency phase distortion
- Excellent phase linearity – even off axis
- Equal sensitivity from front or back of element
- Consistent frequency response regardless of distance
- No power supply required
- Compact size

Electrical Specifications

Acoustic Operating Principle:	Electro-dynamic pressure gradient
Polar Pattern:	Figure-8
Generating Element:	2.5 micron aluminum ribbon
Frequency Range:	30HZ – 15,000HZ \pm 3dB
Sensitivity:	-49dBv Ref 1 v/pa
Output Impedance:	300 Ohms (nominal) balanced
Rated Load Impedance:	> 1500 Ohms
Maximum SPL:	> 135dB
Output Connector:	Male XLR 3 pin (Pin 2 Hot)

All Royer monaural microphones are available in matched pairs.

Mechanical Specifications

High grade Neodymium magnet assembly in Royer's patented Flux-Frame transducer
1.5" x 3/16" x 2.5-micron ribbon assembly

Stainless steel internal baffle and dampener

Weight:	244 grams (8.6 ounces)
Weight with Case:	21.1 ounces
Dimensions:	158mm x 25mm (6.13" L x W)
Finish:	Dull Satin Nickel or Matte Chrome
Accessories:	Protective wood case, protective mic sock
Optional Accessories:	Shock mount, popscreen

To learn more about Royer products and their usage, visit our website at www.royerlabs.com.

Polar Pattern

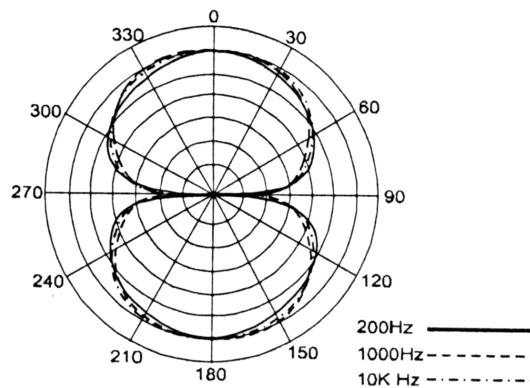

Frequency Response

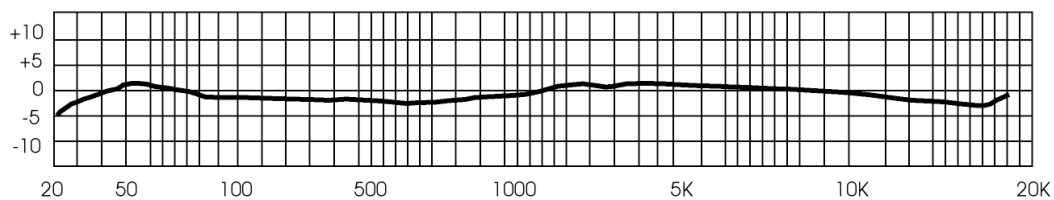

Warranty

PLEASE RETAIN YOUR ORIGINAL BILL OF SALE AS YOU WILL NEED TO PRESENT IT SHOULD YOU REQUIRE SERVICE UNDER THIS WARRANTY.

TO VALIDATE THIS WARRANTY, THE REGISTRATION CARD AND A PHOTOCOPY OF THE SALES RECEIPT FROM AN AUTHORIZED ROYER DEALER MUST BE ON FILE WITH ROYER LABS.

Royer Labs hereby warrants all Royer R-series microphones with the following terms and conditions.

WARRANTY PERIOD

Body fit and finish	Lifetime
Transducer frames/magnets	Lifetime
Transformers	Lifetime
Vacuum Tube	10 years Parts and Labor
Cables & Cable Sets	2 years Parts and Labor
Shock Mount Accessories	2 years Parts and Labor
Ribbon Element	First re-ribbon free

SCOPE OF WARRANTY:

From the date of original purchase and for the respective periods specified above, Royer Labs agrees to repair, at its sole expense, all Royer Labs products which are defective in material and workmanship.

EXCLUSIONS:

This warranty does not cover the following:

1. Defects or damage caused by accident, fire, flood, lightning or other acts of nature.
2. Defects or damage caused by abuse, misuse, negligence or failure to observe the instructions contained in the owner's manual furnished at the time of original purchase.
3. Damage caused during shipping or handling.
4. Products that have had their serial numbers altered or removed.
5. Products purchased in "AS-IS" (used) condition.
6. Products that have been altered or repaired by anyone other than a factory authorized service station.

ROYER Labs
2711 Empire Ave.
Burbank, California 91504
Telephone 818.847.0121
Fax 818.847.0122
www.royerlabs.com