



# VENUE | S6L Handbook

VENUE   S6L Systems	VENUE Hardware Overview	Hardware and Expansion	Resources: Support	Specifications: Weight
Additional Requirements	Configuration 1	E6L Engine	Resources: Training & Documentation	Specifications: Power ●●●●
VENUE Software	Configuration 2	E6L Engine Options	Resources: Social	Specifications: Dimensions ●●●●●
VENUE Plug-Ins	Configuration 3	Stage 64 I/O Rack		Cable Requirements
iLoks and Licenses	Configuration 4	Stage 64 Expansion Options		Other VENUE Systems
VENUE Standalone Software	Dual Systems with I/O Sharing	Stage 16 I/O		
Pro Tools for S6L	Mixed Configurations (Stage 32 and Stage 16)	S6L Control Surface		
Pro Tools AVB Record/Playback	Local 16 I/O Configurations	Personal Monitoring ●●		
MADI Record/Playback				

# VENUE | S6L Systems

Avid VENUE | S6L is a modular live mixing system that delivers unrelenting performance and reliability through its advanced engine design, highly efficient touchscreen workflows and easy scalability. Like all VENUE systems, S6L provides onboard industry-standard plug-ins and Pro Tools integration, with more processing power and track counts than ever before. Plus, with a comprehensive array of network and I/O offerings, including personal monitoring control via [VENUE | On-Stage](#), you can easily configure the system for any application.

Along with the familiar [VENUE software](#), VENUE S6L systems consist of the following hardware components:

1x **S6L Control Surface:** S6L-48D, S6L-32D, S6L-24D, or S6L-24C



S6L-48D



S6L-32D



S6L-24D



S6L-24C



S6L-16C



1x **E6L Engine:** E6L-192, E6L-144, or E6L-112, with 1x AVB-192 Network Card

(One additional AVB-192 card is included with more recent E6L engines (but not pre-installed with some systems or engines.)



## Stage I/O Units:

### Stage 64 (base configuration)

- 48 analog in (via 6x SRI cards)
- 8 analog out (via 1x SRO card)



### Stage 48

- 48 analog in
- 24 analog out



### Stage 32 (base configuration)

- 24 analog in (via 3x SRI cards)
- 8 analog out (via 1x SRO card)



### Stage 16

- 16 analog in
- 8 analog out
- 4 AES digital output channels



## Local I/O Units:

### Local 16

- 8 analog in
- 8 analog out
- 4 pairs of XLR stereo AES/EBU (8 channels total)
- 4 pairs of XLR stereo AES/EBU (8 channels total)



For information on I/O and other expansion options, see [VENUE Hardware Overview](#).

# Additional Required Items

The following items are required and must be purchased separately.

For the most up-to-date list of required items, see the S6L Support FAQ on our Knowledge Base:

<http://avid.force.com/pkb/articles/faq/Avid-S6L-Support>

## DVI-D Monitor, Trackball/Mouse, Keyboard, and Other

### For Day-to-Day Operation:

- Free-standing HDMI or DVI-D compatible Full HD display with 1920 x 1080 minimum resolution (21.5-inch or greater touch display recommended), a DVI-D cable, and a USB cable (for enabling the touch screen function on the monitor).

Note: Use a qualified monitor with your S6L system. Visit

[www.avid.com/S6Lsupport](http://www.avid.com/S6Lsupport) for a list of supported monitors and important cable specifications.

Do not use a USB-powered monitor with your S6L system.

- USB keyboard and mouse/trackball (Windows-compatible recommended)
- If you need more USB ports use a powered USB hub (not a bus-powered or passive hub).

### For Software Installation:

The following items may be required for software installation.

- Windows-compatible USB keyboard and mouse (required for software installation, and highly recommended for operation)
- USB flash drive(s) for user data backup and software installers
- An active hard-wired Internet connection
- A separate computer running Windows XP or higher
- A VGA-compatible monitor, or VGA-to-HDMI adapter, is required for performing a manual VENUE software System Restore or Software Update.

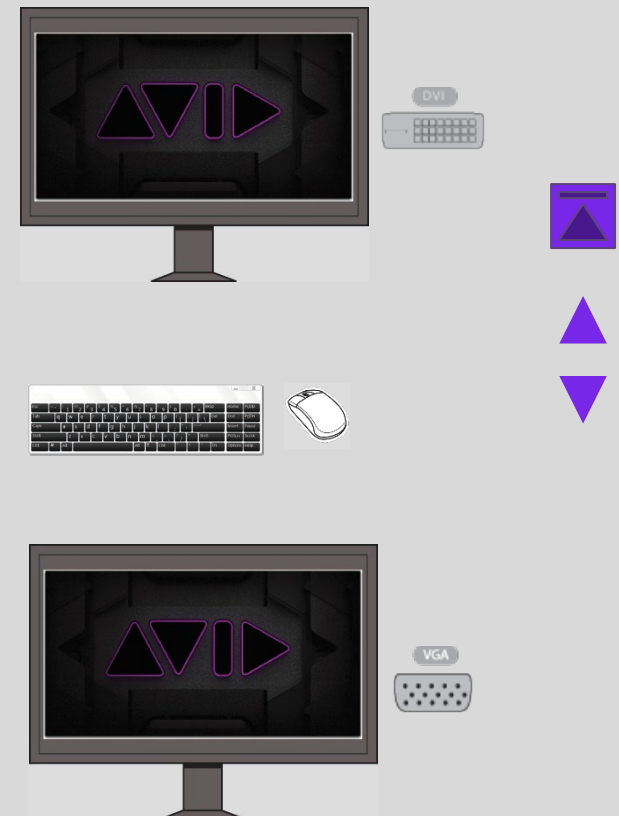

## Cables

For details on cable requirements and support, see [Cabling Requirements](#).

# VENUE Software

## Activation

You must activate each S6L system component using the Activation Card included in each component's shipping package. Activate your S6L control surface first, to have software and documentation placed in your Avid account. Activating your control surface, E6L engine, and I/O units also starts your support contracts for each item. You must also activate Pro Tools using its Activation Card included in the E6L Engine package.

Follow this link to the S6L Learn & Support home page and scroll down to **TUTORIALS** for a video showing how to install and activate VENUE software:

[Installing & Activating VENUE Software](#)



Once you have completed the activation process for all S6L system components, download links for all S6L system software and documentation are available from the <My Products and Subscriptions> section of your Avid account. These items remain in your account after you have downloaded them, in case you need to access them again.

<https://www.avid.com/account>

VENUE software downloads include the following primary elements:

- System Restore for S6L Control Surface
- System Restore for E6L Engine
- Software Update (when available, updates both the E6L Engine and S6L Control Surface)

*Notes:*

- When performing a System Restore you *MUST* download and perform both System Restores (E6L Engine and S6L Control Surface).
- Software Update downloads are available whenever possible, but may not be available for every release. If no Software Update is available, download and perform both System Restores.
- For complete instructions on software installation, including how to backup Show files and settings, see the ***VENUE S6L Installation Guide.pdf*** (available for download in your account after you Activate).

# VENUE Plug-Ins

Each VENUE | S6L System comes with an extensive collection of software plug-ins. Many more are available from Avid and our Development Partners.

VENUE plug-ins let you mix with the same sound processors used in top studios to get the sounds you want. Or recreate an artist's signature studio sound live. Because S6L directly supports Avid and third-party 64-bit AAX DSP plug-ins, you have far more creative choices at your fingertips than any other live mixing system. Plus, you can use many more plug-ins in your mix, including plug-ins for immersive audio, thanks to the system's dedicated, scalable HDX-powered DSP processing.

<http://www.avid.com/products/venue-s6l-system/included-plugins>

For a list of some of the plug-ins compatible with S6L, see:

[S6L Plug-In Compatibility](#)



## Waves SoundGrid

By installing a [WSG-HD Waves SoundGrid Option Card](#) into the E6L engine you can integrate a Waves SoundGrid server hosting Waves plug-ins directly into your S6L system.

# iLoks

Activating your VENUE system deposits iLok licenses in your iLok account.

Activating Pro Tools deposits additional licenses into your iLok account.

Visit [iLok.com](http://iLok.com) to sign-in to your iLok account, or create one if necessary (it's free). Download and install the *iLok License Manager* on a Mac or PC to be able to install and manage your licenses.

Use iLok License Manager to transfer the following licenses to the correct iLok:

**VENUE Plug-in Licenses (such as S6L Plug-In Bundle)** VENUE plug-in licenses must be transferred to your VENUE iLok (the licenses must be present on an iLok connected to your VENUE system). Beginning with VENUE 6.2, all Avid VENUE plug-ins are installed with VENUE software.

**Pro Tools** Your Pro Tools license must be transferred to your Pro Tools iLok alongside the licenses for any Pro Tools plug-ins, and the LiveSound Production Toolkit license (if using Pro Tools 2018.7 or earlier).

**LiveSound Production Toolkit** Beginning with Pro Tools 2018.10, the functionality provided by the Live Sound Production Toolkit is included in Pro Tools and is automatically enabled whenever the Pro Tools Playback Engine is set to E6L (or E3). For maximum compatibility, transfer the Live Sound Production Toolkit to your Pro Tools iLok to enable 64- and 128-channel Pro Tools AVB with Pro Tools 2018.7 or earlier.

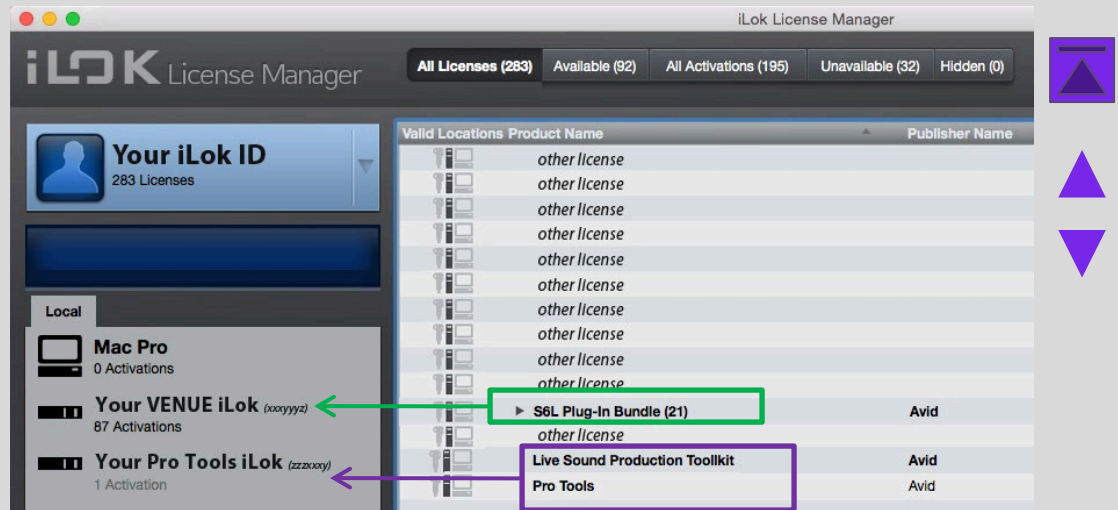

Example iLok account shown in iLok License Manager

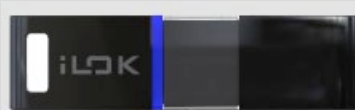

iLok (2<sup>nd</sup> generation)



iLok (3<sup>rd</sup> generation)



**Waves SoundGrid** Licenses for any Waves SoundGrid plug-ins are managed separately. See the documentation provided by [Waves](http://Waves.com) for more information.



# VENUE Standalone Software

VENUE | S6L Standalone software is free and available for download from our Knowledge Base:

<http://avid.force.com/pkb/articles/download/VENUE-Standalone-Software-Updates>

S6L Standalone software lets you do all of the following:

- Learn the basics of the VENUE | S6L software interface to prepare for working at a full VENUE | S6L system.
- Assign hardware I/O and routing, and name channels.
- Set channel input, EQ, dynamics, pan, and other settings.
- Create and maintain a library of setups, with access to nearly all parameters available on the control surface.
- Store and recall Snapshots, and configure Events.
- Use the Filing features to transfer Shows and Shows Folders, as well as channel, processing and plug-in presets to/from a compatible USB storage device to transfer data between the standalone software and VENUE | S6L systems. You can also import snapshots and events from one Show into the current Show file (requires VENUE software version 5.7 or higher).



For system requirements and installation instructions download the ***S6L Standalone Software.pdf***

For examples and tutorials that can be performed in the Standalone software, download the ***Intro to S6L.pdf*** from the S6L documentation resource on our Knowledge Base:

[http://avid.force.com/pkb/articles/user\\_guide/S6L-Documentation](http://avid.force.com/pkb/articles/user_guide/S6L-Documentation)

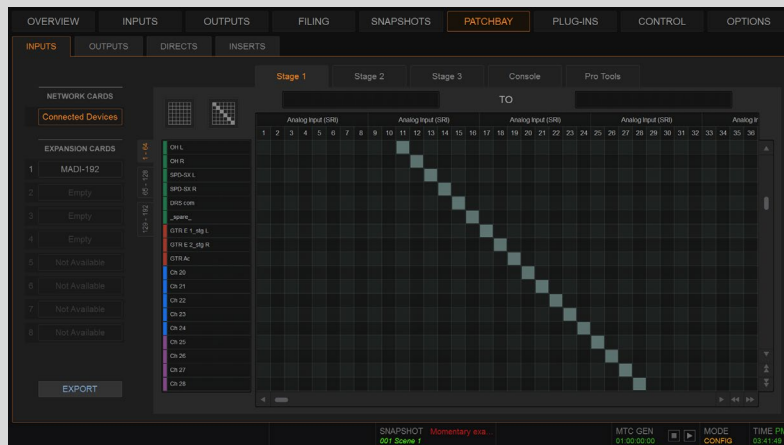

Patchbay in Standalone Software

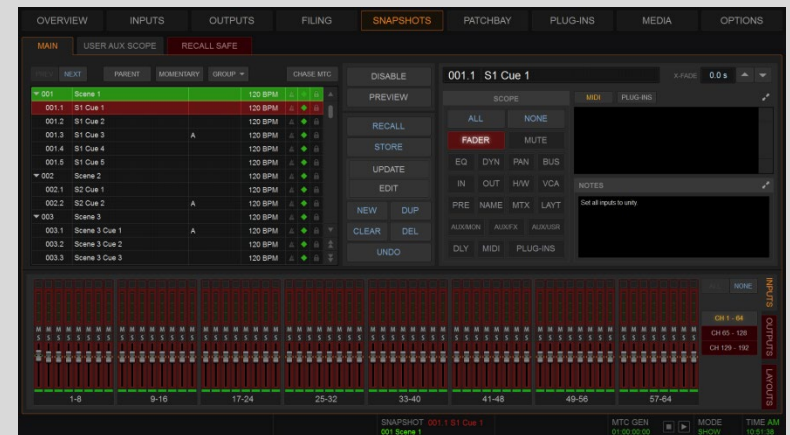

Snapshots in Standalone Software



# Pro Tools for S6L

Each VENUE | S6L System includes Pro Tools and a Pro Tools [iLok](#). Pro Tools Activation and download links are provided in the E6L Engine package. Use these to activate and download Pro Tools Software from your Avid Account to your compatible workstation.

## Important!

For the latest compatibility information, Mac optimizations and other system requirements to use Pro Tools with S6L, refer to this article on our Knowledge Base: [What are the system requirements for Pro Tools with S6L?](#)

When you Activate Pro Tools, its required iLok asset (license) is transferred to your iLok.com account, along with licenses for any included plug-ins. You must then transfer your **Pro Tools** license and any **Pro Tools Plug-in** licenses to your Pro Tools iLok.

**Important: Live Sound Production Toolkit** Beginning with Pro Tools 2018.10, the functionality provided by the Live Sound Production Toolkit is included in Pro Tools and is automatically enabled whenever the Pro Tools Playback Engine is set to E6L (or E3). For maximum compatibility, be sure to also transfer the Live Sound Production Toolkit license to your Pro Tools iLok to enable 64- and 128-channel Pro Tools AVB with Pro Tools 2018.7 or earlier.

## About Virtual SoundCheck

When using Pro Tools with S6L via [Pro Tools AVB](#) or [MADI Record/Playback](#) (requires one or more MADI-192 MADI Option Cards) you get complete Virtual SoundCheck functionality. With Virtual Soundcheck you can get a head start on your mix using Pro Tools recordings from a previous night's performance in place of the live mics. Play back the tracks from a previous performance, adjust the mix, program snapshots and experiment with different plug-ins, and have your changes remain when you switch back to your live mix.

## About VENUELink

VENUELink is a communication protocol that lets you take advantage of the following capabilities:

- Control the Pro Tools transport directly from the S6L control surface.
- Create Pro Tools sessions that automatically populate and name tracks based on VENUE channels.
- Create and link Pro Tools Makers (memory locations) with VENUE Snapshots.
- VENUELink uses the same Ethernet connection to the Pro Tools computer as Pro Tools AVB.

To learn how to integrate Pro Tools recording and playback into your shows with S6L, download the **S6L Live Recording Guide.pdf**:  
[http://avid.force.com/pkb/articles/user\\_guide/S6L-Documentation](http://avid.force.com/pkb/articles/user_guide/S6L-Documentation)







# Pro Tools AVB Record/Playback

## Pro Tools AVB

The S6L system provides direct connection to a computer running Pro Tools software. No additional audio hardware is required to connect your S6L system to Pro Tools.

A single Ethernet connection lets you record multi-track Pro Tools sessions of performances using a variety of S6L system audio sources, including digital splits of your Stage inputs, channel Direct Outputs, and bus outputs. You can also play back multi-track audio from Pro Tools through your S6L system to integrate pre-recorded tracks with your live mix, or to monitor your Pro Tools recording on your S6L system. By combining recording and playback features, you can perform a true Virtual Soundcheck.



### Summary:

- Works out-of-the-box.
- Single Ethernet connection to Pro Tools (Network port **C** on S6L Control Surface to the Pro Tools computer\*).
- Supports up to 128-channel communication with Pro Tools 2018.9 or later and a compatible Pro Tools workstation.
- With Pro Tools 2018.7 and earlier, supports 32 channels of bi-directional audio by default; 64- and 128-channels supported with the LiveSound Production Toolkit license on your Pro Tools iLok, and a compatible Pro Tools workstation.
- 128-channel AVB also requires 2x AVB-192 Network Cards in the E6L Engine.
- Can do splits and/or sub-mixing/stems, supports VENUeLink and true Virtual SoundCheck.
- Beginning with VENUE software 6.1 up to two Pro Tools systems can be connected using Network ports **C** and **D** for redundant recording.

### Requirements:

- If you are using Pro Tools 2018.7 or earlier, both the Pro Tools license *and* LiveSound Production Toolkit licenses *must* be present on the Pro Tools iLok. Both of these licenses are included with the shipping system (if you are renting a system, be sure the Pro Tools iLok with these licenses is included). Beginning with Pro Tools 2018.9, the functionality provided by the Live Sound Production Toolkit automatically enabled whenever the Pro Tools Playback Engine is set to E6L (or E3).
- 128-channel AVB requires 2x AVB-192 Network Cards in the E6L Engine.
- Special system requirements for the Pro Tools computer may apply depending on the number of channels. For the latest compatibility information and system requirements, visit this article on our Knowledge Base:

[What are the system requirements for Pro Tools with S6L?](#)

For examples and step-by-step instructions, download the **S6L Live Recording Guide.pdf**:

[http://avid.force.com/pkb/articles/user\\_guide/S6L-Documentation](http://avid.force.com/pkb/articles/user_guide/S6L-Documentation)

# MADI Record/Playback

In addition to Pro Tools AVB, you can also use either (or both) of the following MADI solutions:

## MADI-192 MADI Option Card

- Requires one or more MADI-192 MADI Option Cards (sold separately) installed in the E6L Engine.
- Great for redundant recording, can do splits and/or stems.
- Supports 48k recording (via SRC on the receiving MADI device).
- Requires one or more Pro Tools | HD MADI IO interfaces, or similar MADI-compatible devices.
- Because the [MADI-192 MADI Option Card](#) provides MADI inputs and outputs, Virtual SoundCheck is supported.

## Stage 64 MADI Splits

- Works out-of-the-box. Each Stage 64 and Stage 32 includes MADI Out connectors for up to 64 MADI channels on Stage 64 and up to 32 on Stage 32.
- Supports direct digital splits of inputs (1-to-1 split of all Stage inputs; no sub-mixing or stems)
- Great for redundant multi-tracking to Pro Tools or other MADI devices (1-to-1 split of Stage inputs only).
- Supports 48k recording (via SRC on receiving MADI device).
- Does not support Virtual SoundCheck (no MADI inputs on Stage 64 or Stage 32).
- Requires one or more Pro Tools | HD MADI IO interfaces, or similar MADI-compatible devices.

For more information, download the ***VENUE S6L Live Recording Guide.pdf***:  
[http://avid.force.com/pkb/articles/user\\_guide/S6L-Documentation](http://avid.force.com/pkb/articles/user_guide/S6L-Documentation)



# VENUE Hardware Overview

VENUE | S6L systems are shipped in the following base configuration.

1x S6L Control Surface (S6L-48D, S6L-32D, S6L-24D, S6L-24C, or S6L-16C)

1x E6L Engine (E6L-192, E6L-144, or E6L-112) with 2x AVB-192 Network Cards. (Early E6L Engines included a single AVB-192 Network Card.)

1 or more Stage I/O Units (Stage 64, Stage 32, Stage 16)

- Additional Stage 64s (up to 3x) can be connected simultaneously (3x requires two AVB-192 Network Cards).
- Stage 32 and Stage 16 I/O boxes, and Local 16 I/O units, can also be used with S6L systems (require two AVB-192 Network Cards).
- AVB-192 Network Cards, IO units, and I/O cards for Stage 64 and Stage 32 are sold separately.
- Additional IO Option cards such as the MADI-192 MADI Option Card, WSG-HD Waves SoundGrid Option Card, and MLN-192 MILAN Option Card can be added to the E6L Engine.

## Example System Configurations, Stage I/O Capacity, and Connection Diagrams

Here are a few example S6L system configurations including single systems, single system expanded IO, Multi-System/IO Sharing setups, redundant star, and configurations with Stage 16s. Follow the “Configuration” links for connection diagrams and additional information on the following pages.



Configuration	Stage Inputs (max)	Stage Outputs (max)	AVB-192 Network Cards in E6L Engine (required)
<a href="#">Configuration 1</a> Base Configuration, 1x Stage 64	64	32	1
<a href="#">Configuration 2</a> Single System , 2x Stage 64	96	64	1
<a href="#">Configuration 3</a> Base Configuration, 3x Stage 16	48	24 analog plus 12 digital	2
<a href="#">Configuration 4</a> Single System Expanded I/O	192	96	2
<a href="#">Configuration 5</a> Multiple Systems for I/O Sharing	192	96	2
<a href="#">Mixed Configurations (Stage 32 and Stage 16s)</a>	varies		2
<a href="#">Redundant Star Configurations</a>	varies		2
<a href="#">Local 16 I/O Configurations</a>	varies		2

# Configuration 1

## Maximum IO Capacity:

Up to 64 Stage Inputs, and up to 32 Stage Outputs

## Requirements for Maximum I/O:

- 1x Stage 64 (8x 8-ch Input cards, 4x 8-ch Output cards)
- 1x AVB-192 Network Card in E6L

## Connections

All connections are made between an “A” port and a “B” port. Examples (shown at left):

- S6L Network port A connects to port B on the E6L.
- E6L port A connects to Stage 64 port B.
- Stage 64 port A connects to S6L Network port B.

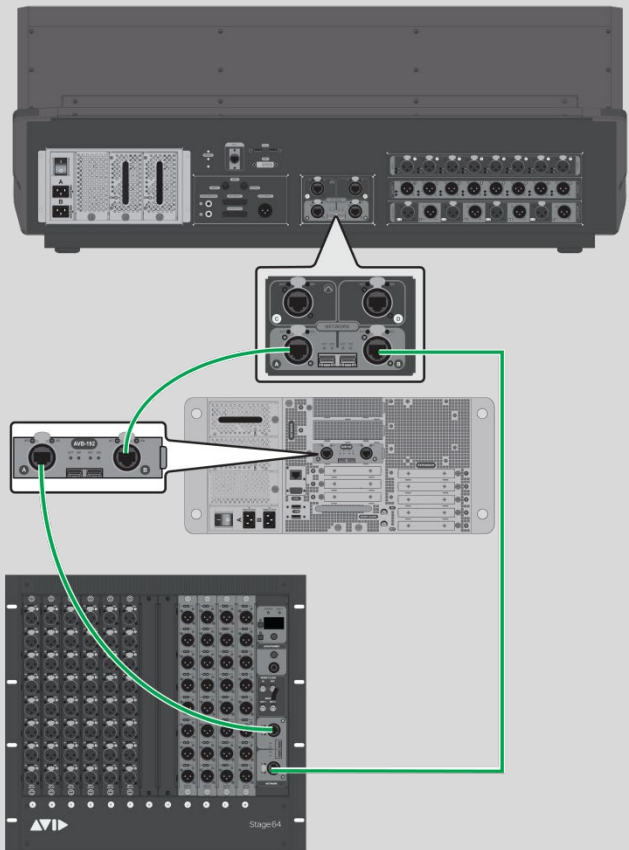

# Configuration 2

## Single System with 2 Stage 64s

### Maximum IO Capacity:

Up to 96 Stage Inputs, up to 64 Stage Outputs

### Requirements for Maximum IO:

- 2x Stage 64s, each with:

Up to 6x 8-ch Input cards

Up to 4x 8-ch Output cards

(Maximum capacity for both Stage 64s. Higher I/O capacity requires two AVB-192 Network Cards in the E6L Engine.)

### Connections

All connections are made between an “A” port and a “B” port.

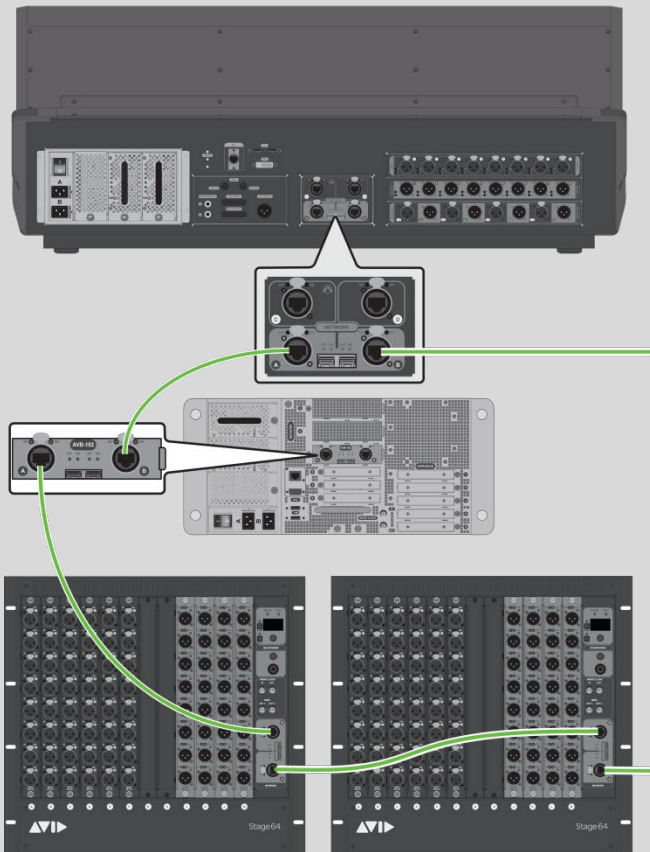

# Configuration 3

## Single System with 3 Stage 16s

### Base Configuration:

48 analog Stage Inputs, 24 analog Stage Outputs, 12 Stage Outputs (digital)

### Requirements:

- 2x AVB-192 Network Cards in E6L (included with S6L 24C-112 Stage 16 systems)

### Connections

All connections are made between an "A" port and a "B" port.

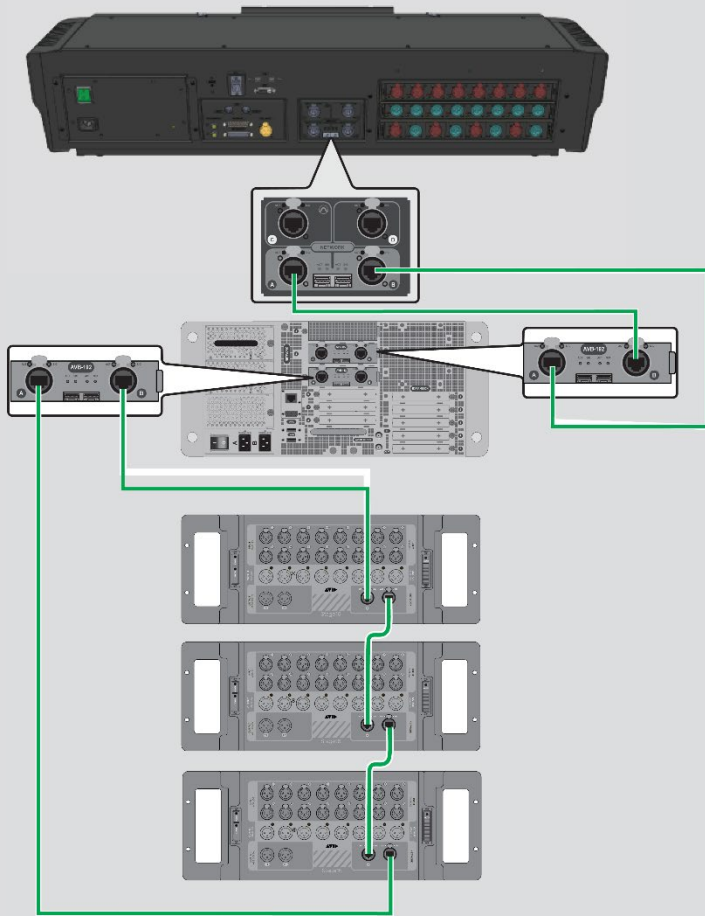

# Configuration 4

## Single System Expanded I/O

### Maximum Expanded IO Capacity:

Up to 192 Stage Inputs, up to 96 Stage Outputs

### Requirements:

- 2x AVB-192 Network Cards in E6L Engine
- 3x Stage 64s, each with:
  - Up to 8x 8-ch Input cards
  - Up to 4x 8-ch Output cards

### Connections

All connections are made between an “A” port and a “B” port.

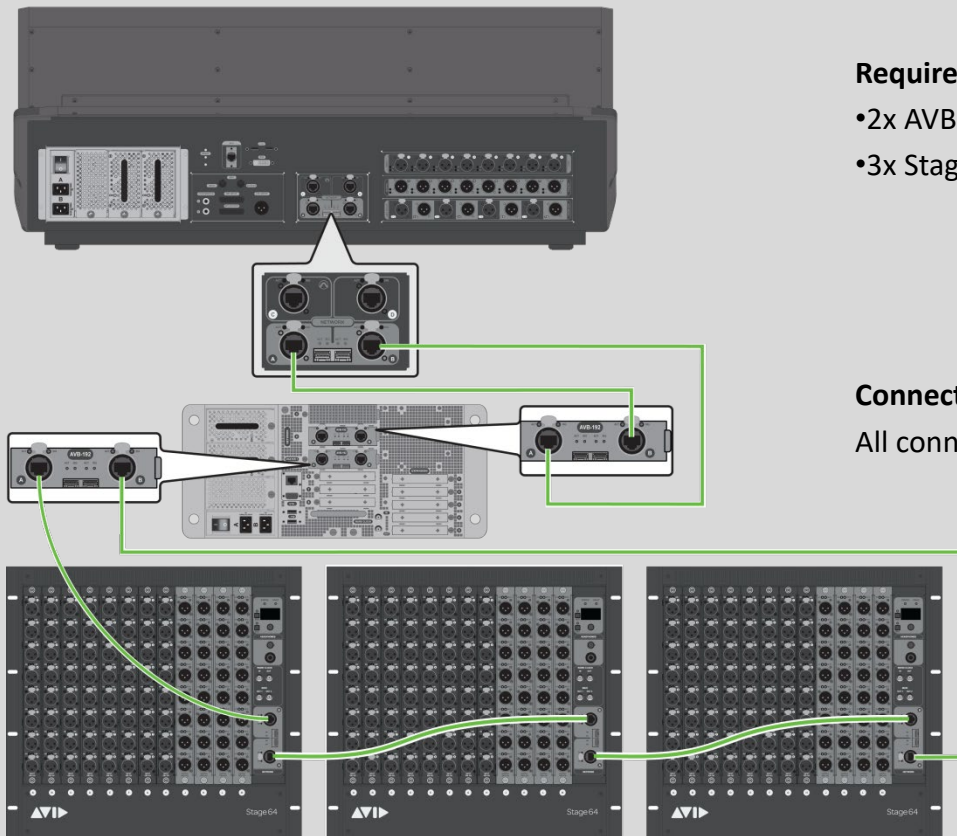



# Configuration 5

## Maximum Expanded IO Capacity:

Up to 192 Stage Inputs, and up to 96 Stage Outputs

## Dual Systems with I/O Sharing, Redundant Ring

### Requirements:

- 2x S6L Control Surfaces
  - 2x E6L Engines, each with 2x AVB-192 Network Cards
  - Up to 3x Stage 64s, each w/ up to 8x 8-ch Input cards, and up to 4x 8-ch Output cards
- Stage 64 Inputs can be shared per-Stage 64; Outputs can be shared per-Output Card.

**Connections** All connections are made between an “A” port and a “B” port.

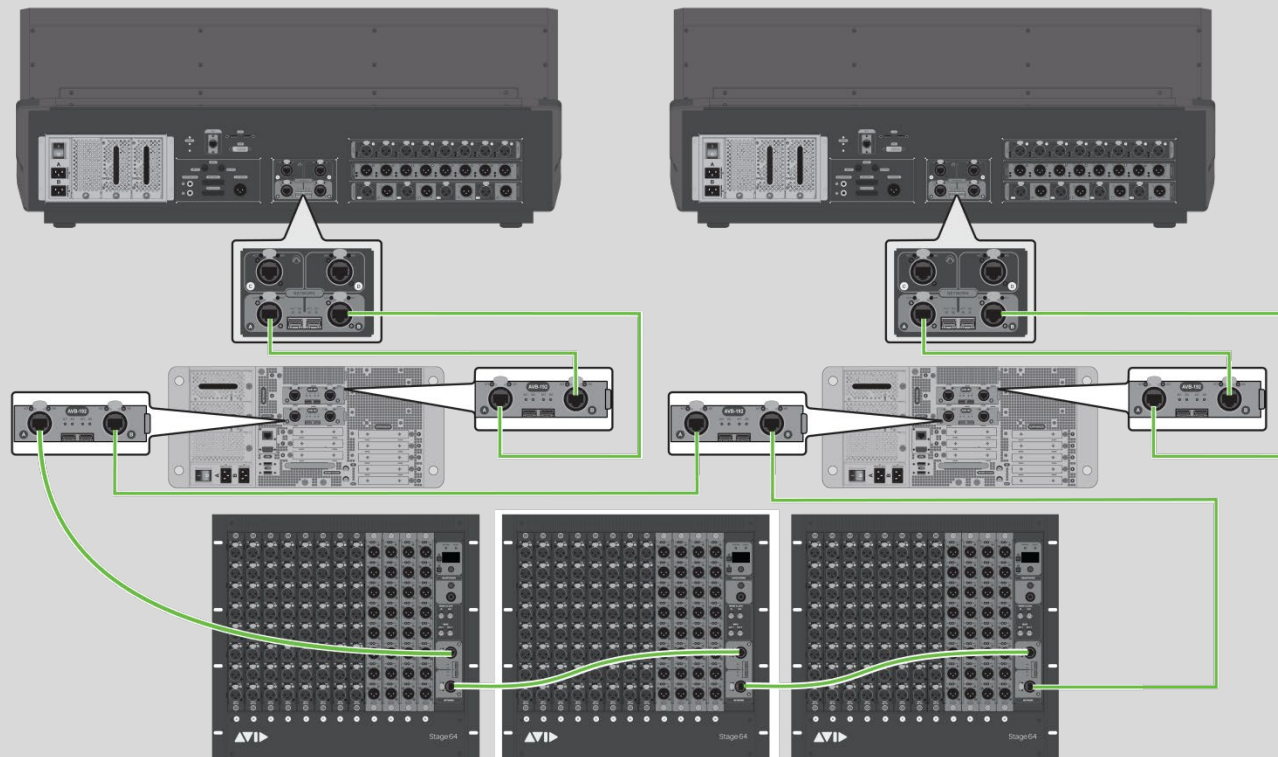

# Mixed Configurations (Stage 32 and Stage 16)

You can use VENUE Stage 32 IO and Stage 16 IO units with S6L systems.

## Requirements:

- 2x AVB-192 Network Cards in E6L Engine(s).
- Stage 32 requires VENUE software 6.0 or later
- Stage 16 requires VENUE software 5.5 or later.

**Connections:** All connections are made between an “A” port and a “B” port.

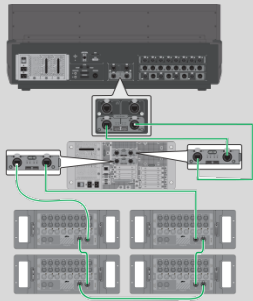

### Maximum I/O Capacity:

- 64 Stage Inputs
- 48 Stage Outputs

### Requirements:

- 2x AVB-192 Network Cards in E6L Engine
- 4x Stage 16s

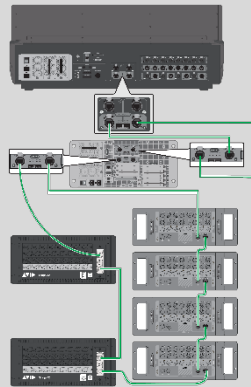

### Maximum I/O Capacity:

- 112 Stage Inputs
- 64 Stage Outputs

### Requirements:

- 2x AVB-192 Network Cards in E6L Engine
- 2x Stage 32s (24in/8out)
- 4x Stage 16s

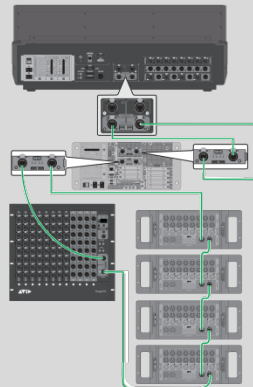

### Maximum I/O Capacity:

- 128 Stage Inputs
- 80 Stage Outputs

### Requirements:

- 2x AVB-192 Network Cards in E6L Engine
- 1x Stage 64
- 4x Stage 16s

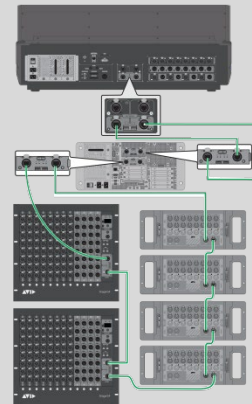

### Maximum I/O Capacity:

- 192 Stage Inputs
- 112 Stage Outputs

### Requirements:

- 2x AVB-192 Network Cards in E6L Engine
- 2x Stage 64
- 4x Stage 16s

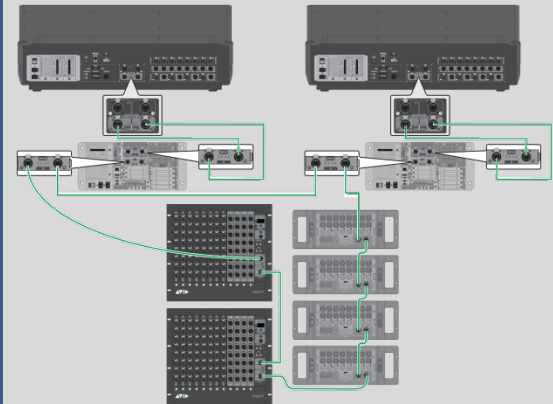

### Dual Systems with I/O Sharing

### Maximum I/O Capacity:

- 192 Stage Inputs
- 112 Stage Outputs

### Requirements:

- 2x AVB-192 Network Cards in both E6L Engines
- 2x Stage 64
- 4x Stage 16s



# AVB Switch Redundant Star Configurations

VENUE 6.3 and later support the use of Luminex GiagCore switches, letting you connect S6L engines and I/O units in a star configuration.

Star configurations provide greater flexibility and increased resilience for system connections. Each I/O unit can be connected with its own simple run of 2x network cables (instead of connecting to the previous or next I/O unit as done in a standard S6L redundant ring network), and units can be powered down, removed, or added without breaking redundancy. (Redundant ring network configurations, required for all earlier S6L releases and as shown in other configuration diagrams in this guide, are also still fully supported.)

**Important!** Before you can use Luminex switches for S6L star configurations, make sure you have all of the following:

- VENUE software version 6.3 or later (for 2x I/O Sharing) or VENUE 7.0 or later (for 3x I/O sharing)
- 2x AVB-192 Network Cards in all E6L Engine(s)
- Highest-quality Cat5e or better Ethernet (copper), or fiber-optic cables
- 2x qualified Luminex switches (see [this article](#) on our Knowledge Base for the current list)
- Both switches *must* be updated to the required firmware, configured, and connected as described in the *S6L Luminex Switch Configuration.pdf*, available for download from the following article our Knowledge Base: [http://avid.force.com/pkb/articles/user\\_guide/S6L-Documentation](http://avid.force.com/pkb/articles/user_guide/S6L-Documentation)

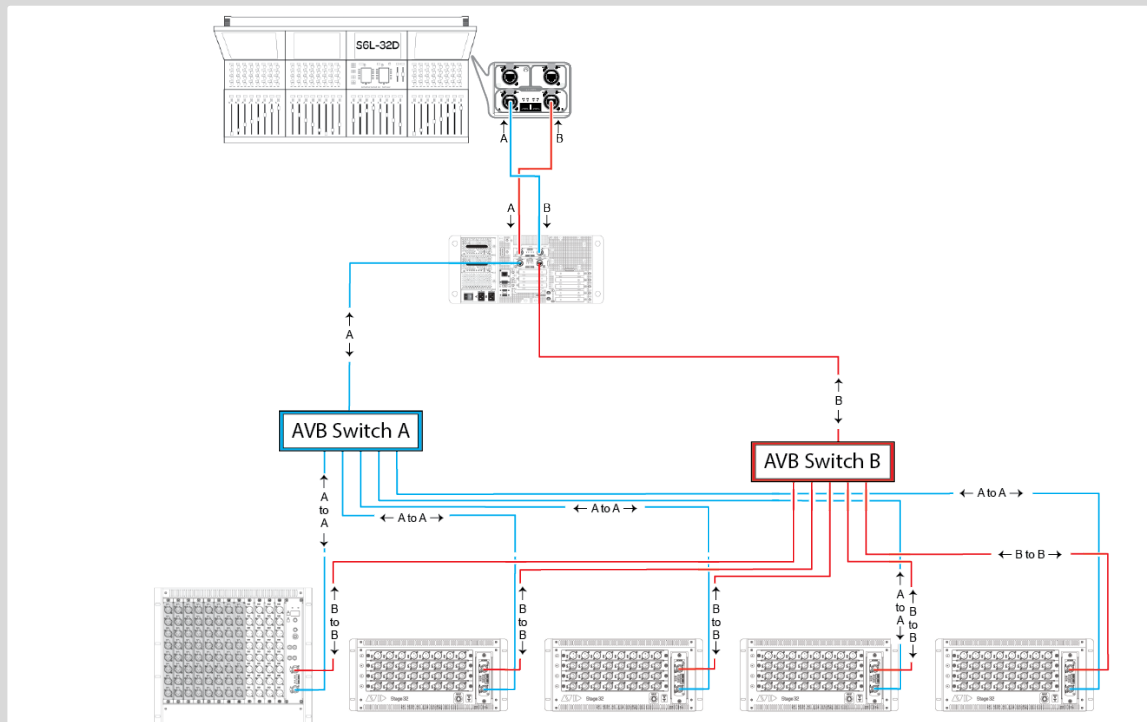

Example single S6L system in a redundant star configuration



# AVB Switch Redundant Star Configurations

## Up to Three Systems with I/O Sharing, Redundant Star

VENUE 7.0 and later supports connecting up to 3 S6L systems for I/O Sharing in a redundant star configuration using qualified network switches.



### Maximum Expanded IO Capacity:

Up to 192 Stage Inputs, and up to 96 Stage Outputs

### Requirements:

- 3x S6L Control Surfaces
- 3x E6L Engines, each with 2x AVB-192 Network Cards
- Up to 3x Stage 64s, each w/ up to 8x 8-ch Input cards, and up to 4x 8-ch Output cards. Stage 64 Inputs can be shared per-Stage 64; Outputs can be shared per-Output Card.
- Qualified Luminex Gigacore switches

### Connections

Control surface-to-engine connections are made between an "A" port and a "B" port.

Engine-to-switch and switch-to-IO connections are made from "A" to "A" and "B" to "B"

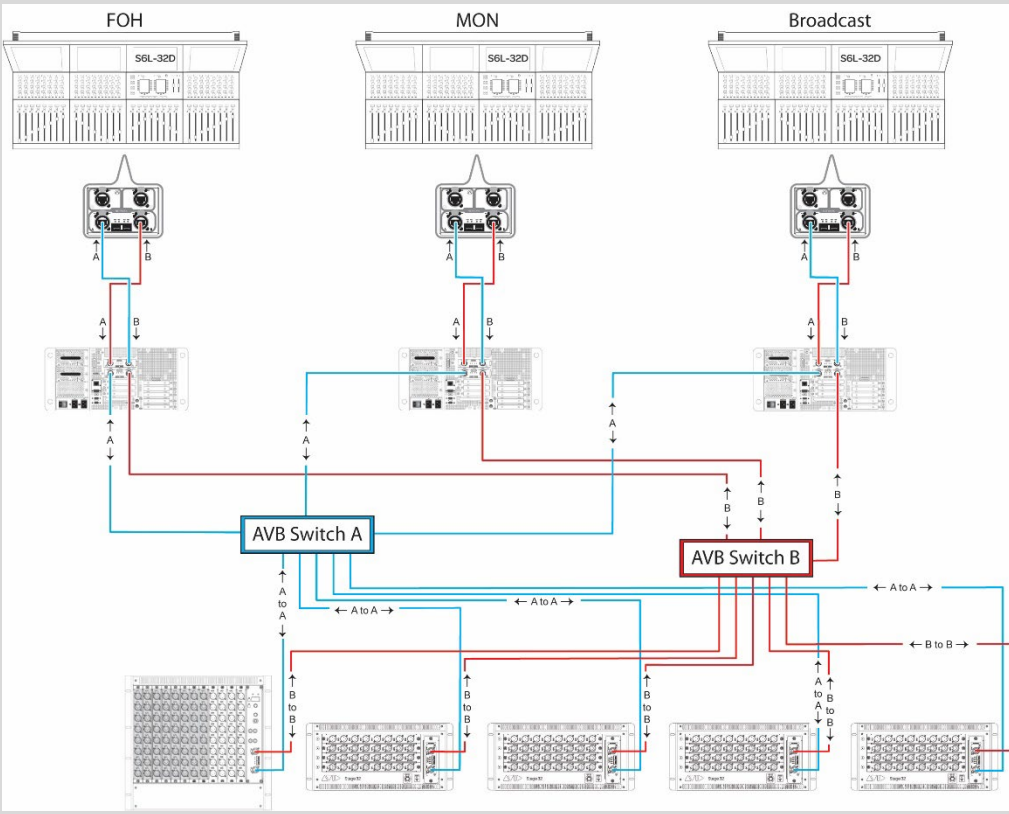

# MLN-192 MILAN Configurations

VENUE 7.0 and later support the MLN-192 Milan Option Card for E6L engines, providing AVB connection to 3rd-party Milan devices.

MILAN™ is a certified format of AVB that guarantees interoperability with other MILAN-certified devices. The MILAN format was created in conjunction with Avid, D&B, L-Acoustics, Meyer, and others as a sample accurate, plug-and-play network format.

Features and capabilities of the MLN-192 Milan Option Card for Avid VENUE | S6L systems include:

- Transmits and receives 128 channels of audio over AVB-Milan at 96 kHz
- Supported with all E6L engines
- Facilitates audio signal distribution on an AVB network in multi-venue installations
- Provides connection to 3rd-party AVB devices to distribute audio over the AVB network
- Allows S6L system-to-system routing (such as between front of house and monitors, or broadcast) of up to 128 channels
- When combined with S6L support for star network topologies, MLN-192 lets you create a distributed I/O model in theaters, houses of worship, and performance venues

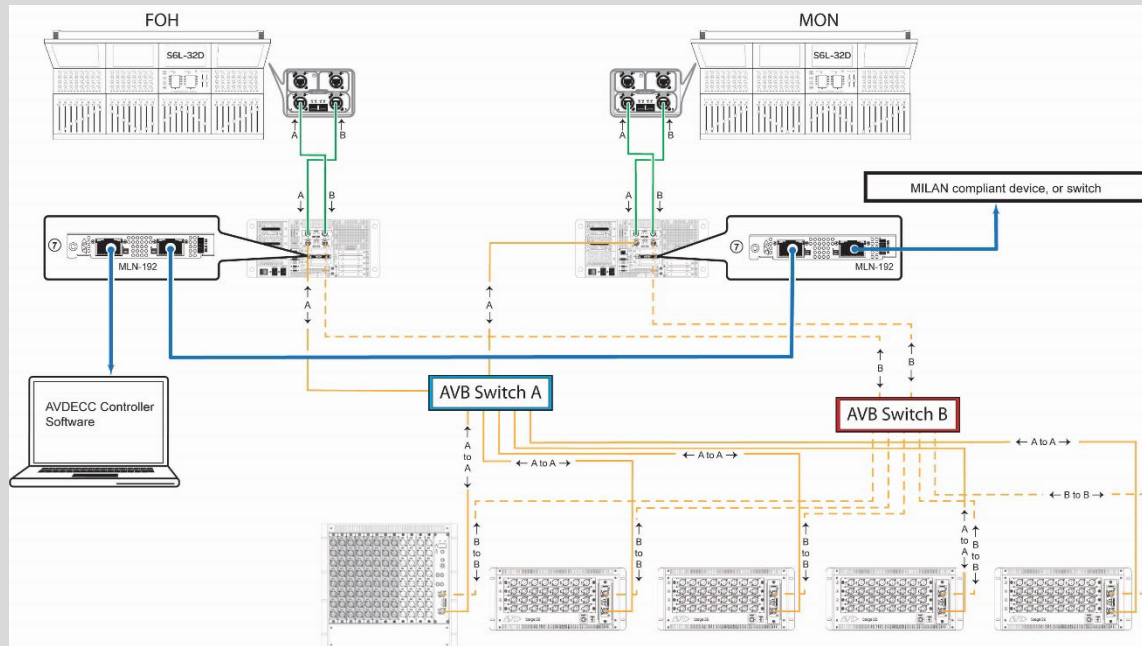

*Example S6L systems in a redundant star configuration, interconnected using MLN-192*



# Local 16 I/O Configurations

Local 16 I/O can be added to provide I/O at the local mix position. Up to two Local 16s can be used with S6L-16C. Other S6L control surfaces support a single Local 16.

## Requirements:

- 2x AVB-192 Network Cards in the E6L engine

**Connections** All connections are made between an “A” port and a “B” port. Local 16 must be connected to the console network ring as shown below.

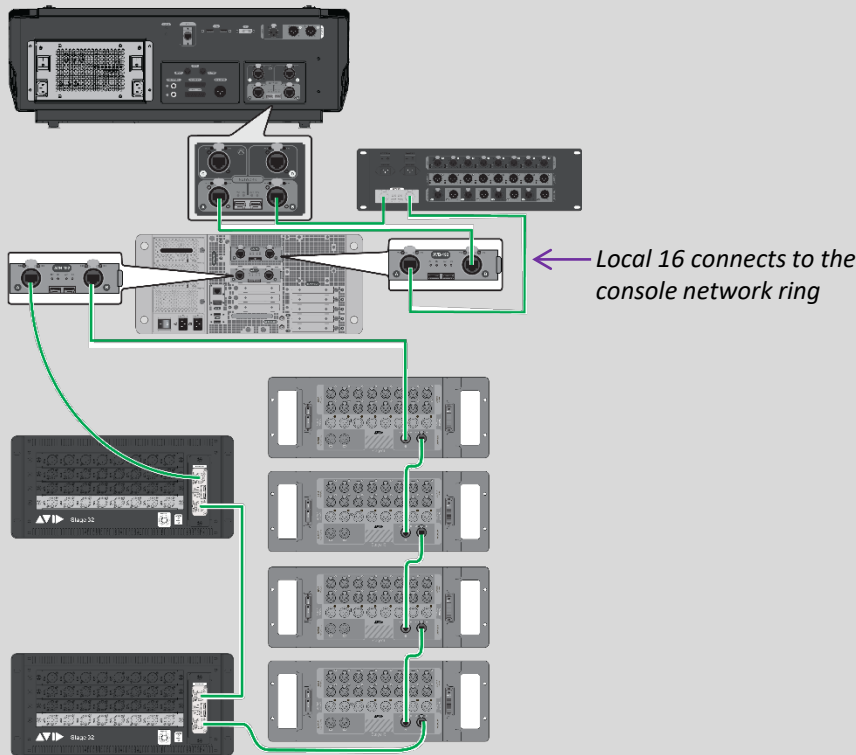

*S6L-16C control surface, 2x Stage 32s, 4x Stage 16s, and one Local 16*

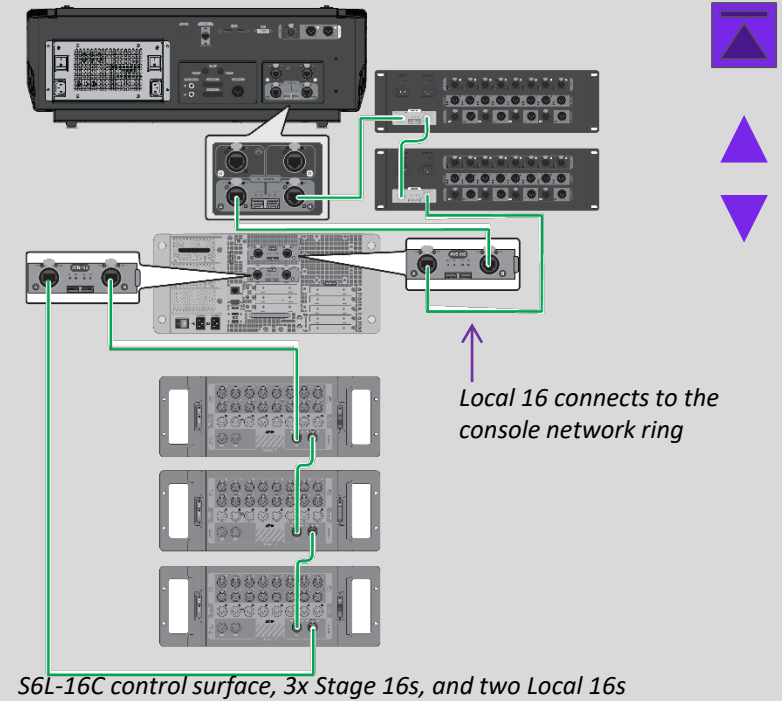



# Hardware Components and Expansion Options

Follow the links below for descriptions of each S6L hardware component and available expansion options. S6L hardware components can be expanded for increased plug-in processing, stage or local I/O.

[E6L Engine](#)



[Stage 64 I/O Rack](#)



[Stage 32](#)



[Stage 16](#)



[S6L Control Surface](#)



[Local 16 I/O](#)





# E6L Engine

E6L Engines are available in three configurations, E6L-192, E6L-144, and E6L-112.



The following table describes the capabilities of each E6L Engine.

Engines	E6L-192	E6L-144	E6L-112
Input Channels	192	144	112
Mix Busses	96 + LCR	64 + LCR	48 + LCR
Ethernet AVB (Network)	2x AVB-192 Network Card (1x AVB-192 Network Cards included in original E6L Engines)		
HDX-192 DSP Cards (Processing)	1 (Maximum of 4)	1 (Maximum of 2)	1 (Maximum of 2)
Option Cards (Expansion Maximums, must be purchased separately)	<ul style="list-style-type: none"> <li>Up to 4x MADI-192 Option Cards (64 ch. each, for a maximum of up to 256 channels of MADI at 96 kHz)</li> <li>1x WSG-HD Waves SoundGrid Option Card</li> <li>1x MLN-192 MILAN Option Card</li> </ul>		E6L-112 (only): <ul style="list-style-type: none"> <li>Up to 2x MADI-192 Option Cards (64 ch. each, for a max. of 128 channels of MADI at 96 kHz)</li> <li>Or 1x MADI-192 and 1x WSG-HD</li> <li>Or 1x MADI-192 and 1x MLN-192</li> <li>Or 1x WSG-HD and 1x MLN-192</li> </ul>



- 2x AVB-192 Network Cards are required for each of the following:
- [Single system Expanded I/O](#)
  - [I/O Sharing](#)
  - [Stage 32 I/O, Stage 16 I/O, Local 16 I/O,](#)
  - [AVB 128-channel Virtual Soundcheck recording/playback](#)

# E6L Engine Expansion Options



## AVB-192 Network Cards

Each E6L includes at least one AVB-192 Network Card for connecting the E6L to other components in the system. Some systems, such as the S6L-24C-112 Stage 16, and newer E6L engines, include two AVB-192 Network Cards. You can add a second AVB-192 card to expand the IO capability of the system by adding Stage I/O units, to connect multiple systems to utilize I/O sharing (shared stage inputs and gain tracking), and for 128-channel Pro Tools AVB Virtual Soundcheck. For installation instructions, see the *AVB-192 Network Card Guide*.



## MADI-192 MADI Option Cards

The MADI-192 MADI Option Card is a high-channel-count, 96 kHz (only) MADI audio interface card for E6L engines. Each MADI-192 MADI Option Card provides four MADI BNC connectors (2x coaxial in, and 2x coaxial out). Each pair of coaxial MADI inputs and outputs supports up to 32 channels of 96 kHz audio per I/O pair. Up to four MADI-192 Option Cards can be installed in an E6L-192 or E6L-144 engine. Up to two MADI Option cards can be installed in an E6L-112 engine. For installation instructions, see the *MADI-192 Card Installation Guide*.



## WSG-HD Waves SoundGrid Option Cards

The WSG-HD Waves SoundGrid Option Card from Avid lets you integrate Waves SoundGrid processing directly into your VENUE | S6L mixes. Once the WSG-HD Card is installed in your E6L engine, plug-ins hosted on the Waves SoundGrid server appear on the VENUE Plug-Ins screen inside of the Waves SoundGrid Rack plug-in (up to 8 plug-ins per instance of SoundGrid Rack). Up to two compatible Waves SoundGrid servers can be connected simultaneously for redundancy with automatic fail-over. The WSG-HD Card requires VENUE software version 5.7 or higher. For hardware installation instructions see the *WSG-HD Card Installation Guide*.



## MLN-192 MILAN Option Card

The MLN-192 Milan Option Card for E6L engines provides AVB connection to 3rd-party MILAN-compliant devices. The MLN-192 card can transmit and receive 128 channels of audio over AVB-Milan at 96 kHz and is supported with all E6L engines. MLN-192 facilitates audio signal distribution on an AVB network in multi-venue installations, provides connection to 3rd-party AVB devices to distribute audio over the AVB network, and allows S6L system-to-system routing of up to 128 channels. When combined with S6L support for star network topologies, MLN-192 lets you create a distributed I/O model in theaters, houses of worship, and performance venues

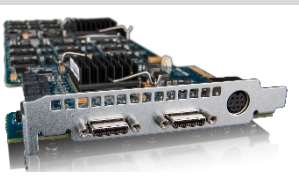

## HDX-192 DSP Expansion Cards

HDX-192 DSP Expansion Cards provide the DSP resources for plug-in processing. All E6L Engines include a single HDX-192 DSP Expansion Card. You can install up to 4x HDX cards in E6L-192 Engines, and up to 2x HDX cards in E6L-144 and E6L-112 Engines.

For installation instructions, see the *HDX-192 Card Installation Guide*.

# Stage 64 I/O Rack

Each Stage 64 I/O Rack ships from the factory with the following I/O:

- 48 analog inputs (XLR balanced) via 6x SRI Analog Input cards
- 8 analog outputs (XLR balanced) via 1x SRO Analog Output card
- 64 MADi splits (output channels) Coax

Additional inputs and outputs can be added to Stage 64 I/O Racks by installing [Stage I/O Expansion Options](#).

Pairs of Stage 64 analog and digital I/O can be used as hardware inserts (any matched pairs on any cards; Stage 64 MADi outs do not support use as hardware inserts).

Up to 3x Stage 64s can be connected simultaneously (requires 2x AVB-192 Network Cards in the E6L Engine).



Stage 64 I/O Racks can also be purchased empty (no pre-installed I/O cards) to be customized with whatever combination of analog and digital IO is needed.

# Stage 48 I/O Rack

The Avid Stage 48 Remote I/O Rack lets you connect 48 analog inputs and 24 analog outputs in a rack. Features include:

- 48 channels of analog input Analog mic/line inputs via XLR-3 female connectors
  - +48V phantom power, 20 dB pad, and phase reverse (all selectable per channel via the control surface and VENUE software)
  - Signal and phantom power LEDs for each channel
  - 24-bit A/D conversion, up to 192 kHz sample rate
- 24 channels of analog output
- Analog line outputs via male XLR-3 connectors
  - Automatic muting for system protection
  - Signal and Mute LEDs for each channel
  - 24-bit D/A conversion
- 64 MADI splits (output channels) Coax



# Stage 32 I/O

Beginning with VENUE 6.0 you can use Avid Stage 32 I/O racks with S6L systems.

Each Stage 32 provides the following I/O in its base configuration:

- 3x SRI cards for 24 analog inputs with remotely controllable mic preamps and individually selectable phantom power
- 1x SRO card for 8 analog outputs
- 32 MADIs (output channels) Coax

Stage 32s are modular and expandable. Analog or digital I/O cards can be installed in any combination up to a maximum of 32 in or 32 out, analog or digital (see [Stage I/O Expansion Options](#)).

## Requirements

- To use Stage 32s with S6L systems, two AVB-192 Network Cards must be installed in all E6L Engines.
- No more than two Stage 64s can be connected whenever any Stage 32 is present.



Stage 32 I/O Racks can also be purchased empty (no pre-installed I/O cards) to be customized with whatever combination of analog and digital IO is needed.



# Stage I/O Expansion Options

Additional inputs and outputs can be added to Stage 64 and Stage 32 I/O units by installing Stage I/O Expansion cards.

**Stage 64** Each Stage 64 I/O Rack has a maximum I/O capacity of:

- 64 analog and/or digital input channels (up to 8x 8-channel Input cards, maximum)
- 32 analog and/or digital output channels (up to 4x 8-channel Output cards, maximum)

**Stage 32** Analog or digital I/O cards can be installed in Stage 32s in any combination up to a maximum of 32 in or 32 out, analog or digital.

Here are the available analog and digital I/O cards you can install in Stage 64 and Stage 32:

## SRI-192 Analog Input Cards



- Eight channels of analog mic/line inputs via XLR-3 female connectors
- +48V phantom power, 20 dB pad, and phase reverse (all selectable per channel via the control surface and VENUE software)
- Signal and phantom power LEDs for each channel
- 24-bit A/D conversion, up to 192 kHz sample rate

## DSI-192 Digital Input Cards



- Eight channels of digital inputs via four two-channel AES/EBU XLR3-female connectors or a single ADAT TOSLINK optical connector
- Automatic sample rate conversion (SRC) and detection on input; manually defeatable for lowest possible input latency
- SRC and Lock status LEDs for both AES and ADAT connections
- Word clock output for synchronizing external digital devices

## SRO-192 Analog Output Cards



- Eight channels of analog line outputs via male XLR-3 connectors
- Automatic muting for system protection
- Signal and Mute LEDs for each channel
- 24-bit D/A conversion

## DSO-192 Digital Output Cards



- Eight channels of digital outputs via four two-channel AES/EBU XLR3-male connectors and/or a single ADAT TOSLINK optical connector
- Simultaneous output to both AES/EBU outputs and ADAT optical output
- Automatic muting for system protection
- Signal and Mute LEDs for each AES/EBU channel pair

## DNT-192 Network Cards



- Sixteen channels of digital input or output, or eight input and eight output channels (Stage 64 only), for connecting to Dante network devices.
- The DNT-192 Network Card supports SRC (sample rate conversion) between the S6L and the Dante network sample rate



For more information on S6L Option cards, visit:

[Avid VENUE | S6L System Options](#)

For S6L documentation, including expansion I/O cards:

[Avid S6L Documentation](#)

# Stage 16 I/O

Beginning with VENUE 5.5 you can use Avid Stage 16 I/O racks with S6L systems.

Each Stage 16 provides the following I/O:

- 16 analog inputs with remotely controllable mic preamps and individually selectable phantom power
- 8 analog outputs
- 4 AES digital output channels (on two stereo connectors)

## Requirements

- To use Stage 16s with S6L systems, two AVB-192 Network Cards must be installed in all E6L Engines.
- No more than two Stage 64s can be connected whenever any Stage 16 is present.



For descriptions and diagrams of supported setups, see [Mixed Configurations \(Stage 32 and Stage 16\)](#).





# Local 16 I/O

Beginning with VENUE 6.1 you can use Local 16 I/O units with S6L systems.

Each Local 16 provides the following I/O:

- 8 analog inputs with remotely controllable mic preamps and individually selectable phantom power
- 8 analog outputs
- 4 pairs of XLR stereo AES/EBU (8 channels total)
- 4 pairs of XLR stereo AES/EBU (8 channels total)

## Requirements

- To use Local 16s with S6L systems, two AVB-192 Network Cards must be installed in all E6L Engines.
- S6L-16C systems support up to two Local 16s. All other systems support a maximum of one Local 16.
- Local 16 connects to the control surface network ring (Ring 2) using copper (RJ-45) or fiber.



For descriptions and diagrams of supported setups, see [Local 16 I/O Configurations](#).



# S6L Control Surfaces

S6L Control Surfaces are available in the following configurations.



CONTROL SURFACE	S6L-48D	S6L-32D	S6L-24D	S6L-24C	S6L-16C
12-inch daylight-visible touchscreens	1 Master Touchscreen, 5 Channel Touch Modules	1 Master Touchscreen, 3 Channel Touch Modules	1 Master Touchscreen, 2 Channel Touch Modules	1 Master Touchscreen	none (requires user-provided external touchscreen)
Faders	48 + 2	32 + 2	24 + 2	24 + 2	16 + 2
Knob Modules with high-resolution OLEDs and tri-color function indicators	160 assignable knobs across 5 Channel Knob Modules	96 assignable knobs across 3 Channel Knob Modules	64 assignable knobs across 2 Channel Knob Modules	32 assignable knobs across 1 Channel Knob Module	32 assignable knobs across 1 Channel Knob Module
Master Live Module	Graphic TFTs with soft buttons; Touch and Turn assignable encoder; 2 assignable faders; monitoring, layout and snapshot controls; transport controls and function buttons				
Metering	30-segment meters per channel, with pre- and post-fade metering options; Nominal indicator, Expander/Gate status and Compressor/Limiter gain reduction meters				
Analog inputs	8 XLR mic/line inputs with 48V and signal present LEDs				1 XLR mic/line input*
Analog outputs	8 XLR outputs with mute and signal present LEDs				2 XLR outputs*
Digital inputs	4 pairs of XLR stereo AES/EBU (8 channels total)				none*
Digital outputs	4 pairs of XLR stereo AES/EBU (8 channels total)				none*
Headphone outputs	2 independent 1/4" TRS stereo headphone jacks				1 1/4" TRS stereo headphone jack
Ancillary I/O	DVI-D video out, 5 USB 2.0 (2 rear, 2 front, 1 internal), ECx Ethernet port for wired/wireless remote control, GPIO (8 in/8 out), 2 footswitch, Linear Time Code input, MIDI I/O				
Ethernet AVB ports	2 etherCON (copper), 2 selectable as etherCON (copper) or SFP (fiber); redundant ring topology				
Power supply	Dual redundant, internal hot-swappable PSUs			Dual redundant, internal	
Height (front, rear)	3.6, 15.3 inches (91, 388 mm)			3.6, 8 inches (91, 205 mm)	
Width	76.1 inches (1,934 mm)	51.3 inches (1,304 mm)	38.9 inches (989 mm)	38.9 inches (989 mm)	26.4 inches (671 mm)
Depth	31 inches (787 mm)				
Weight	238 lbs (108 kg)	155 lbs (70 kg)	119 lbs (54 kg)	84 lbs (38 kg)	70.5 lbs (32 kg)

\* Local 16 can supply additional local I/O

For descriptions and diagrams of supported configurations see the [VENUE S6L Installation Guide.pdf](#).



# Personal Monitoring

Avid VENUE | On-Stage

## Personal Mix Control with VENUE | On-Stage

Avid VENUE | On-Stage app for iPad and iPhone lets performing artists remotely control master level, and level and pan of each member channel feeding a selected Aux monitor mix or Mains.

VENUE | On-Stage easily connects to a supported VENUE | S6L (or VENUE | S3L-X) system via Wi-Fi. Using compatible iPads and iPhones, up to 16 instances of On-Stage can be connected simultaneously. Access to mixes can be controlled with passwords.

## Installation and Setup

1. On-Stage is available free from [the App Store](#). On each compatible device, search for VENUE On-Stage and click *Get*.
2. Using an Ethernet cable, connect a Wi-fi router to the ECx port on the S6L control surface (or E3 Engine on S3L-X systems).
3. Connect your iOS device(s) to the wireless network associated with the router that is connected to your VENUE system.
4. Launch On-Stage as you would any app on your mobile device (tap its icon). →  On-Stage finds all S6L/S3L-X systems on the Wi-Fi network and displays the Connect screen.

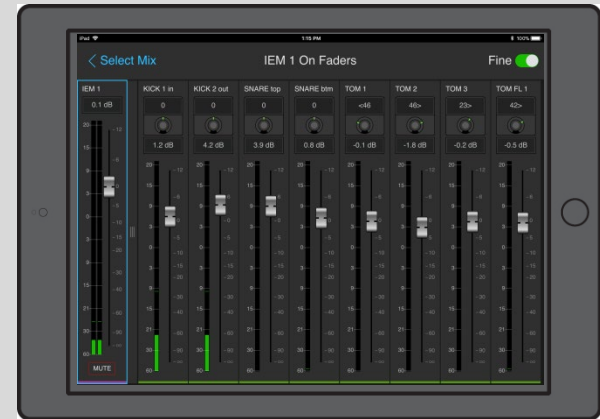
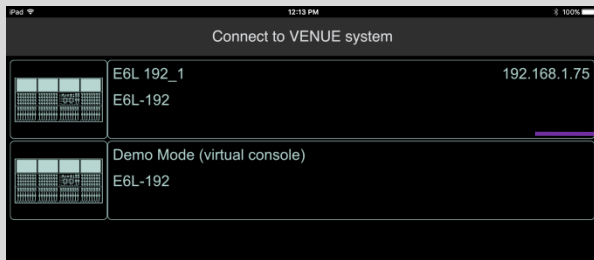

Mix screen for a select Aux

In the Mix screen:

- Drag faders to adjust channel volume. Enable Fine mode for greater resolution.
- To see more channels, swipe right or left.
- To adjust pan, tap a pan display then adjust the on-screen knobs.
- To hide the Master, swipe the “grip” icon to the left (swipe to the right to show a hidden Master).
- To adjust a different mix, tap *Select Mix*.

For more information, see the *VENUE On-Stage.pdf*.

5. On the Connect screen, tap to choose one of the listed systems. The Select Mix screen appears.

(If you don't see your VENUE system listed, go to Options > Interaction. In the Ethernet Control section, make sure the system is configured to get its IP Address Automatically.)

6. To select a mix, tap its tile. The Mix screen appears for the selected Aux (or Mains).

# Personal Monitoring

## Audio Distribution



### Audio Distribution

You can easily connect your personal monitoring solution of choice to S6L, using any available analog, AES, TOSLINK, MADI, or Dante™ outputs.

Integrating S6L's 96k native digital audio with external 48k gear is easy. You can use the built-in MADI Out on each Stage 64 (configure it for 48k). Keep in mind that the built-in MADI Out on Stage 64 provides 1-to-1 splits of inputs only (no stems or sub-mixing).

S6L's flexible patching makes it easy to send any channel or combination of channels (including Auxes, Group outs, and custom Matrix mixes) to any available output. Patching can be stored and recalled via Snapshots, with extensive control of Aux Sends and nearly all other system parameters.



For more information on available personal monitoring solutions and how to choose the best one for you, consult your Avid Authorized Reseller.



# Remote Control

ECx Ethernet Remote Control, and VENUE | Function app

In addition to VENUE On-Stage, you can also use ECx and the VENUE Function app to remotely control aspects of your system.

**ECx Ethernet Control** lets you remotely control your system over a wired or wireless Ethernet network. With ECx you can access all controls and pages shown on the S6L external screen from a laptop, tablet, or other compatible device. For more information see the *ECx Ethernet Control Guide*.

**VENUE | Function Pad app** for iOS lets you access Function switch assignments from your iPad or iPhone, letting you remotely access any Event-based Function switch assignment. Typical uses for the Function app include controlling the Pro Tools transport and/or recalling VENUE snapshots while checking monitor mixes from the stage, and banking the secondary zone when in Dual Operator mode.

VENUE | Function easily connects to a supported VENUE | S6L system using Wi-Fi. Up to 16 instances of the Function app can be connected simultaneously. For more information, see the *VENUE Function.pdf*.

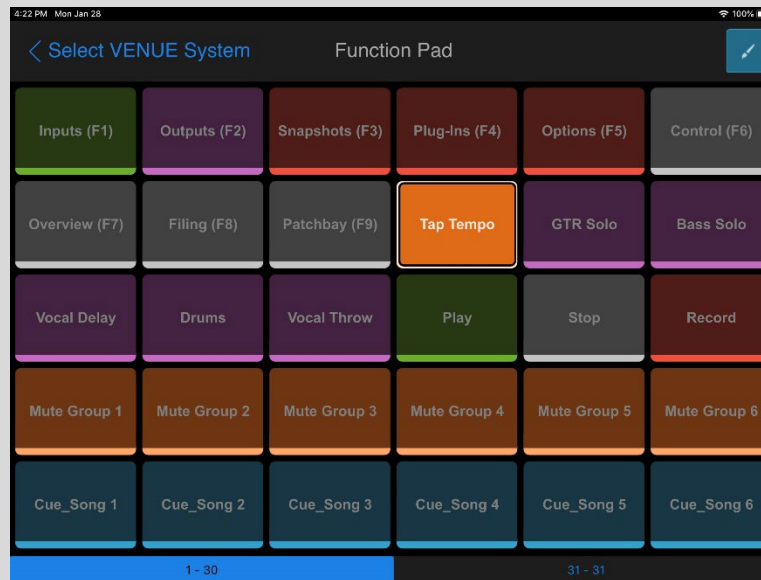

VENUE Function Pad app

# Resources: Support and Customer Care

To contact Avid support and for information about Support Plans visit:

[Contact Audio & Music Support](#)

For information and links for downloads, activation and registration, Knowledge Base, resources (documentation, data sheets, brochures, and similar), training, community resources, repairs and warranty, and video resources, visit:

[VENUE | S6L Systems Learn & Support](#)



## VENUE Live Sound Hotline

If you need emergency support, call us.

Please have your System ID ready when you call.

Americas	Europe	Asia
US and LATAM: +1 978-275-2557	Europe: +44 1753 659 500	Korea: +82 2 782 4215 China: +86 10 57306096 Japan: +81 3-3505-6138

# Resources: Training and Documentation

## Training and Curriculum

[Find a VENUE Training Course](#)

## Webinars (Video Training and Interviews on Avid.com)

<http://www.avid.com/live-sound-webinars>

## Live Sound Videos (More Live Sound Video Resources on Avid.com)

<http://www.avidblogs.com/live-sound-videos/>

## YouTube

To watch S6L experts from Avid demonstrate many of the topics covered in this guide, follow links provided in each topic, or check out all videos on the [Avid Live Sound](#) channel on YouTube.

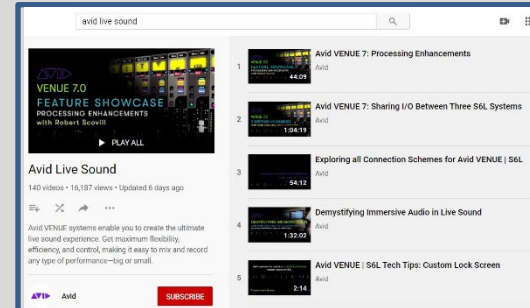

## Documentation

Beginning in VENUE 7, official S6L documentation is provided on the system (Options > Help). You can also download the latest editions of all user guides for S6L from your [Avid Account](#) and from the [S6L Documentation](#) site on our Knowledge Base. Here are descriptions of some of the most useful guides available there:

- *VENUE | S6L Installation Guide.pdf* provides complete hardware and software installation instructions, including how to activate and download VENUE software and how to perform a software System Restore and a Software Update.
- *Intro to S6L.pdf* is for first-time users of Avid VENUE | S6L systems. It introduces the main components of the system and gives you practical experience with inputs, signal routing, processing, and more. Along the way you'll find links to many of our videos on YouTube and the Avid web site that demonstrate each topic and provide additional information.
- *VENUE | S6L System Guide.pdf* provides complete operational information for using the system day-to-day, including patching and signal routing, snapshots, recording and playing back with Pro Tools, Show file management, Events, and more.
- *S6L Live Recording Guide.pdf* includes examples and step-by-step instructions for live recording, Virtual Soundcheck, integrated Pro Tools playback and more.
- Hardware-specific guides show how to install and integrate I/O expansion cards and options. Hardware guides include the *AVB-192 Network Card Installation.pdf*, *Stage 64 I/O Card Installation.pdf*, and guides for the HDX-192 DSP Expansion Card, MADI-192 MADI Option Card, DNT-192 Dante Option Card, WSG-HD Waves SoundGrid Option Card, and other options.
- Check the latest *What's New in VENUE.pdf* for information about each software release.

## General

For information and links for downloads, activation and registration, Knowledge Base, resources (including documentation, data sheets, brochures, and similar), training, community resources, repairs and warranty, and video resources, visit:

[VENUE | S6L Systems Learn & Support](#)



# Resources: Community and Social

Take advantage of the following resources to participate in the ever-growing S6L global community, and contribute to the development of current and future Avid products.

User Conferences ([Avid Pro Audio Community](#) for Pro Tools, [VENUE](#), and Other Avid Audio Products)

## Social



[Avid Live Sound blogs](#)



[Avid Live Sound FaceBook](#)



[Avid LiveSound Twitter](#)



# Specifications: Weight

## Weight

### Control Surfaces

	S6L-48D	S6L-32D	S6L-24D	S6L-24C	S6L-16C
<b>Weight</b>	212 lbs (96 kg)	154.5 lbs (70 kg)	119 lbs (54 kg)	84 lbs (38 kg)	70.5 lbs (38 kg)

### Engines

	E6L-192/144	E6L-112
<b>Weight</b>	74 lbs (33.5 kg)	71 lbs (32 kg)

### Stage I/O Units

	Stage 64	Stage 48	Stage 32	Stage 16
<b>Weight</b>	Empty: 46 lbs (20.8 kg) Full: 69 lbs (31.2 kg)	35 lbs (76 kg)	Full: 49 lbs (22 kg)	21 lbs (9.5 kg)

### Local I/O

	Local 16
<b>Weight</b>	16.3 lbs (7.4 kg)



# Specifications: Power

## S6L Control Surface

### Power

S6L-48D will use slightly more, while S6L-24D, S6L-24C, and S6L-16C will use slightly less, power than shown below for S6L-32D.



#### S6L-32D Power Measurements, 110V/60Hz

Parameter	Measurement	Units	Accuracy ( $\pm$ )	Notes
RMS Input Voltage	110	VAC	0.05% + 0.25V	
Frequency	60	Hz	0.1% $\pm$ 1 digit	
RMS Input Current	2.425	A	0.1% + 0.15A	
Peak Input Current	61.188	A	0.2% + 0.5A	Internally limited by AC supply
Crest Factor	1.64		1.5%	
VA (Reactive) Power	267.8	VA	0.15% + 9 VA	
Real Power	257.8	W	0.15% + 9 W	
Power Factor	0.97		0.03	
Current THD	20.65	%A		EN61000-3-2 Class A compliant



#### S6L-32D Power Measurements, 220V/50Hz

Parameter	Measurement	Units	Accuracy ( $\pm$ )	Notes
RMS Input Voltage	220	VAC	0.05% + 0.25V	
Frequency	50	Hz	0.1% $\pm$ 1 digit	
RMS Input Current	1.317	A	0.1% + 0.15A	
Peak Input Current	61.188	A	0.2% + 0.5A	Internally limited by AC supply
Crest Factor	1.68		1.5%	
VA (Reactive) Power	288.8	VA	0.15% + 9 VA	
Real Power	261.6	W	0.15% + 9 W	
Power Factor	0.91		0.03	
Current THD	16.65	%A		EN61000-3-2 Class A compliant

(Measured @100VAC)

# Specifications: Power

## E6L Engine

### Power

E6L Engine Configuration: E6L-192, with 1x AVB-192 Network Card and 1x HDX DSP Card.

Add 0.3 A for each HDX-192 DSP Card.



#### E6L-192 Engine Power Measurements, 110V/60Hz

Parameter	Measurement	Units	Accuracy ( $\pm$ )	Notes
RMS Input Voltage	110	VAC	0.05% + 0.25V	
Frequency	60	Hz	0.1% $\pm$ 1 digit	
RMS Input Current	2.157	A	0.1% + 0.15A	
Peak Input Current	52.023	A	0.2% + 0.5A	Internally limited by AC supply
Crest Factor	1.66		1.5%	
VA (Reactive) Power	237.3	VA	0.15% + 9 VA	
Real Power	226.7	W	0.15% + 9 W	
Power Factor	0.96		0.03	
Current THD	18.77	%A		
RMS Input Voltage	110	VAC	0.05% + 0.25V	



#### E6L-192 Engine Power Measurements, 220V/50Hz

Parameter	Measurement	Units	Accuracy ( $\pm$ )	Notes
RMS Input Voltage	220	VAC	0.05% + 0.25V	
Frequency	50	Hz	0.1% $\pm$ 1 digit	
RMS Input Current	1.261	A	0.1% + 0.15A	
Peak Input Current	55.999	A	0.2% + 0.5A	Internally limited by AC supply
Crest Factor	1.54		1.5%	
VA (Reactive) Power	277.6	VA	0.15% + 9 VA	
Real Power	228.5	W	0.15% + 9 W	
Power Factor	0.82		0.03	
Current THD	18.88	%A		

(Measured @100VAC)

# Specifications: Power

## Stage 64/Stage 32

### Power

Stage 64 Configuration: 6x SRI Analog Input Cards, x1 DSI Digital Input Card, 3x SRO Analog Output Cards, 1x DSO Digital Output Card. Actual power consumption can vary depending on the number and type of cards installed. ○ ○ ○ ●

Stage 32 power consumption will be less than Stage 64.

### Stage 64 I/O Rack Power Measurements, 110V/60Hz

Parameter	Measurement	Units	Accuracy (±)	Notes
RMS Input Voltage	110	VAC	0.05% + 0.25V	
Frequency	60	Hz	0.1% ± 1 digit	
RMS Input Current	1.829	A	0.1% + 0.15A	
Peak Input Current	52.023	A	0.2% + 0.5A	Internally limited by AC supply
Crest Factor	1.59		1.5%	
VA (Reactive) Power	201.0	VA	0.15% + 9 VA	
Real Power	197.0	W	0.15% + 9 W	
Power Factor	0.98		0.03	
Current THD	18.73	%		EN61000-3-2 Class B compliant



### Stage 64 I/O Rack Power Measurements, 220V/50Hz

Parameter	Measurement	Units	Accuracy (±)	Notes
RMS Input Voltage	220	VAC	0.05% + 0.25V	
Frequency	50	Hz	0.1% ± 1 digit	
RMS Input Current	0.928	A	0.1% + 0.15A	
Peak Input Current	52.023	A	0.2% + 0.5A	Internally limited by AC supply
Crest Factor	1.58		1.5%	
VA (Reactive) Power	204.0	VA	0.15% + 9 VA	
Real Power	195.4	W	0.15% + 9 W	
Power Factor	0.96		0.03	
Current THD	21.22	%		EN61000-3-2 Class B compliant

(Measured @100VAC)

# Specifications: Power

## Stage 16/Local 16

### Power

Stage 16 measurements taken using 0dBFS level on all analog output channels.

Phantom power load of 4mA placed on 13 of 16 input channels.

Local 16 power consumption will be similar to Stage 16.

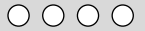

### Stage 16 I/O Rack Power Measurements, 110V/60Hz

Parameter	Measurement	Units	Accuracy ( $\pm$ )	Notes
RMS Input Voltage	110	VAC	0.05% + 0.25V	
Frequency	60	Hz	0.1% $\pm$ 1 digit	
RMS Input Current	0.37	A	0.1% + 0.15A	
Peak Input Current	50.0	A	0.2% + 0.5A	Internally limited by AC supply
VA (Reactive) Power	44.0	VA	0.15% + 9 VA	
Real Power	43	W	0.15% + 9 W	
Power Factor	0.96		0.03	



*(Measured @100VAC)*

# Dimensions: S6L-48D

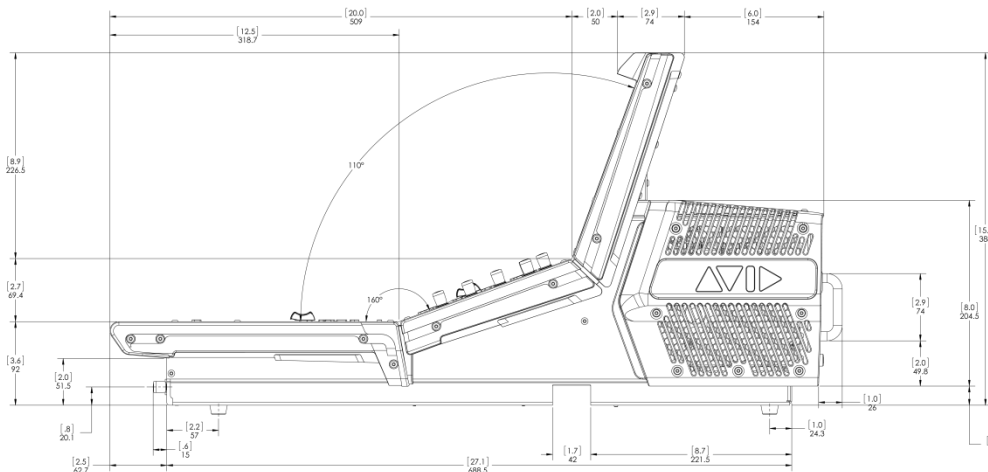
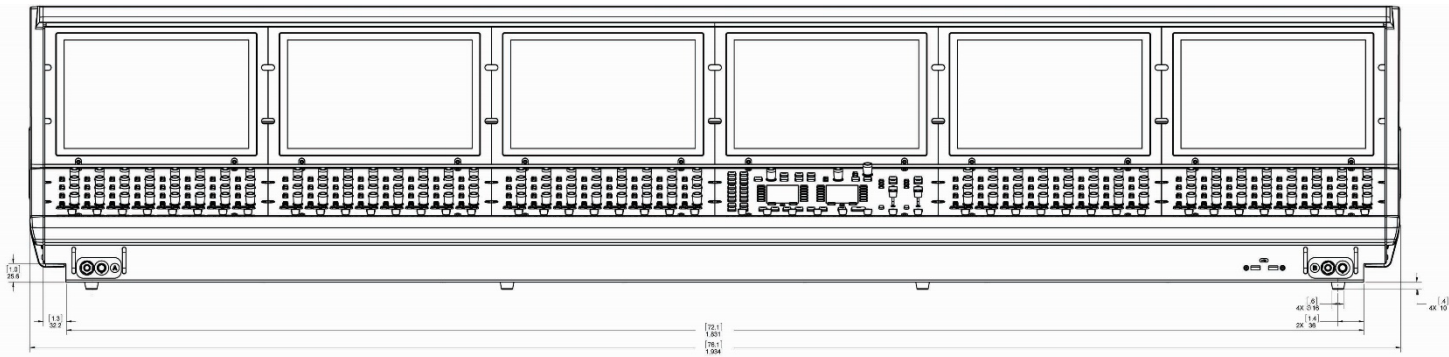

Parameter	Specification
Maximum Height, Front	3.6 inches (92 mm)
Maximum Height, Back	15.3 inches (388 mm)
Maximum Width	76.1 inches (1934 mm)
Maximum Depth	31 inches (786.5 mm)

You can download DXF line drawings of all S6L hardware components from the [S6L Documentation](#) article on our Knowledge Base.



# Dimensions: S6L-32D

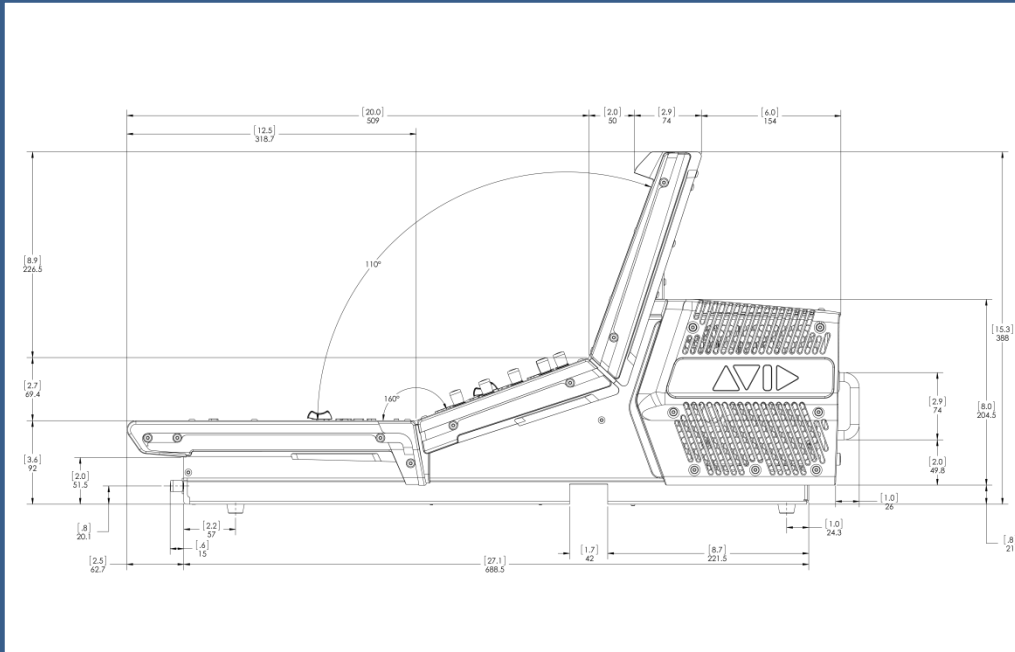
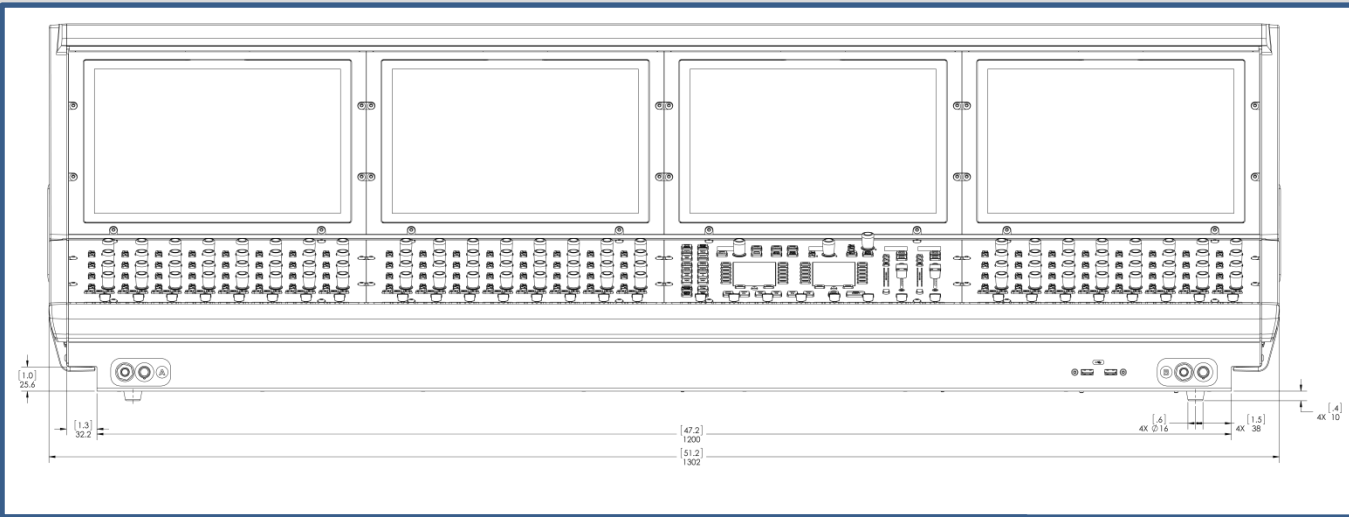

Parameter	Specification
Maximum Height, Front	3.6 inches (92 mm)
Maximum Height, Back	15.3 inches (388 mm)
Maximum Width	51.2 inches (1302 mm)
Maximum Depth	31 inches (786.5 mm)

You can download DXF line drawings of all S6L hardware components from the [S6L Documentation](#) article on our Knowledge Base.

# Dimensions: S6L-24D/24

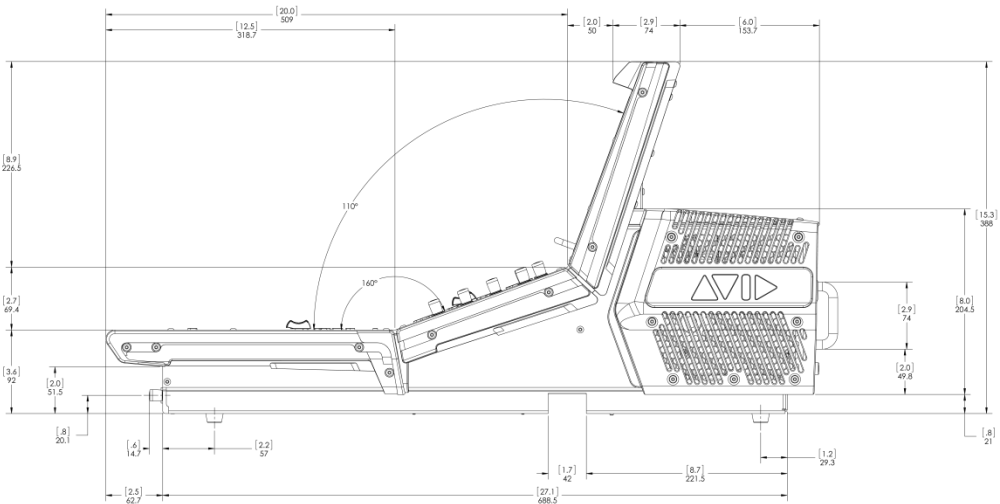
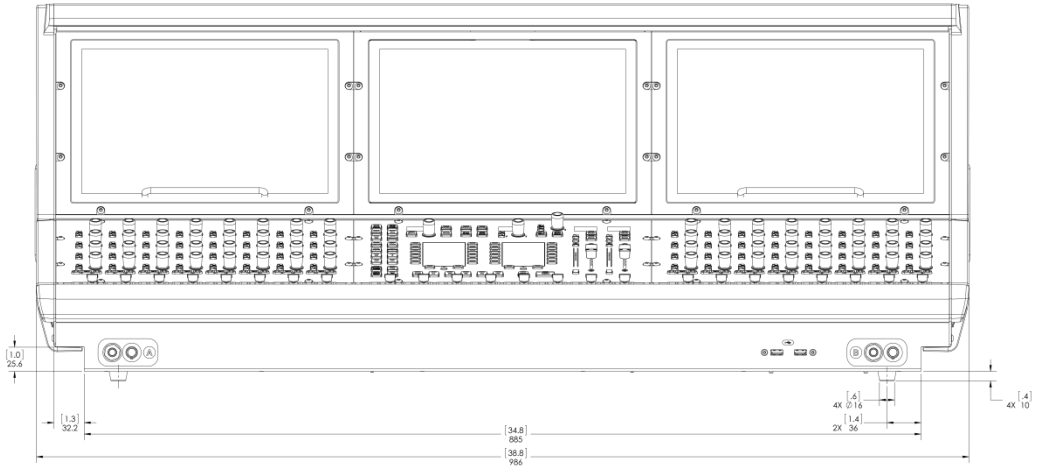

Parameter	Specification
Maximum Height, Front	3.6 inches (92 mm)
Maximum Height, Back	15.3 inches (388 mm)
Maximum Width	38.8 inches (986 mm)
Maximum Depth	31 inches (786.5 mm)

You can download DXF line drawings of all S6L hardware components from the [S6L Documentation](#) article on our Knowledge Base.



# Dimensions: S6L-16C

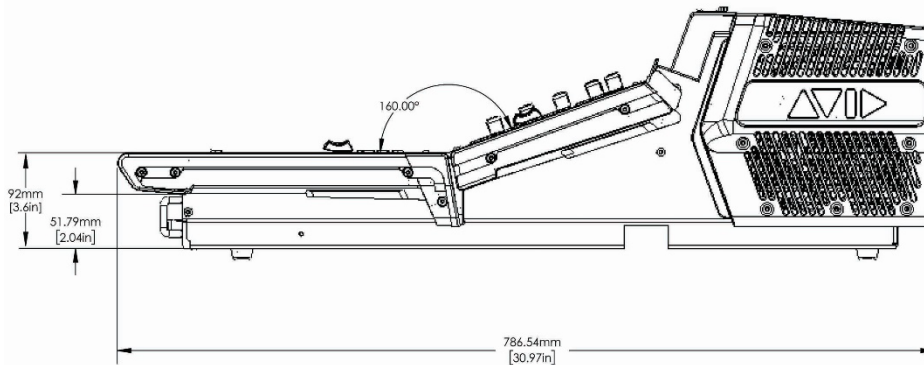
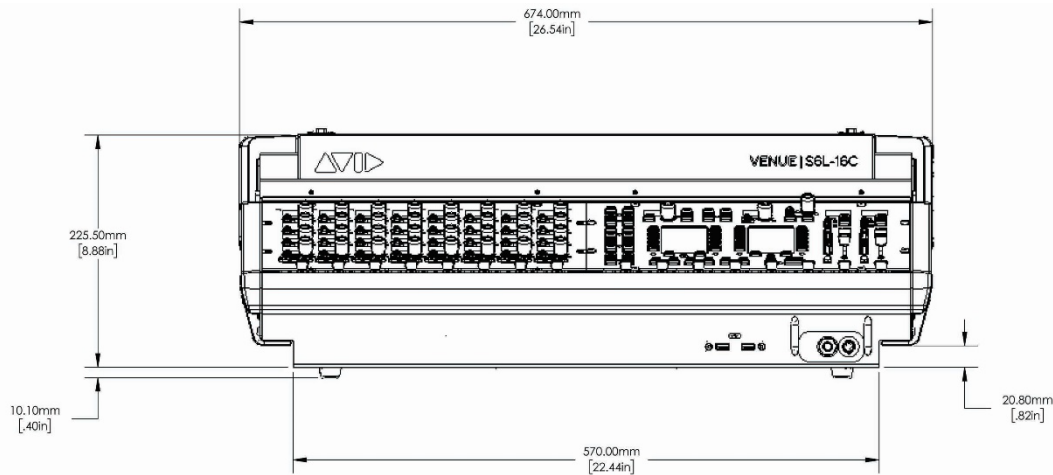

Parameter	Specification
Maximum Height, Front	3.6 inches (92 mm)
Maximum Height, Back	8 inches (205mm)
Maximum Width	26.5 inches (674 mm)
Maximum Depth	31 inches (786.5 mm)

You can download DXF line drawings of all S6L hardware components from the [S6L Documentation](#) article on our Knowledge Base.

# Dimensions: E6L Engine

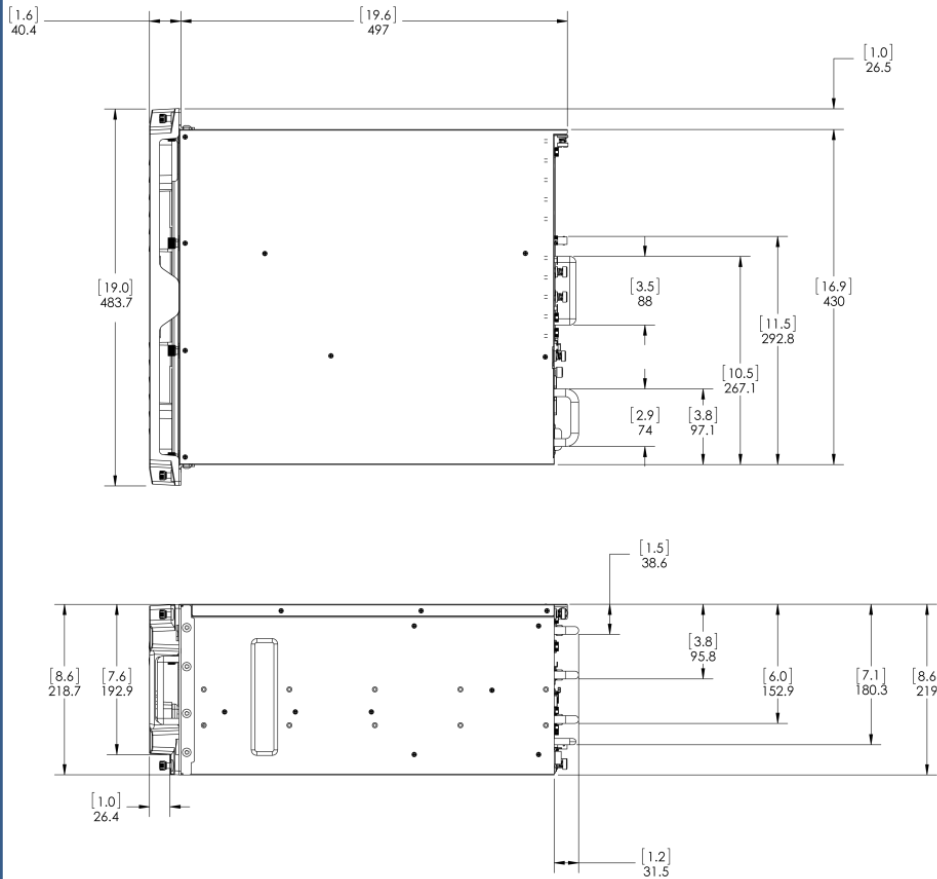

Parameter	Specification
Maximum Height	8.6 inches (218.7 mm)
Rack Spaces	5U
Maximum Width	19 inches (483 mm)
Depth with Bezel	21.2 inches (537 mm)
Depth without Bezel	19.6 inches (497 mm)

You can download DXF line drawings of all S6L hardware components from the [S6L Documentation](#) article on our Knowledge Base.

# Dimensions: Stage 64

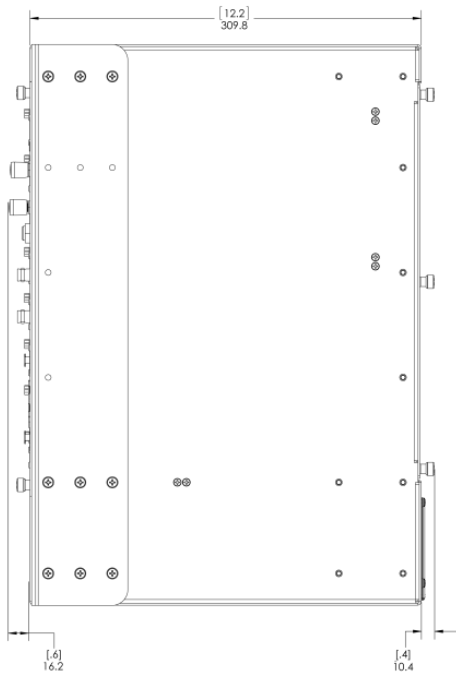
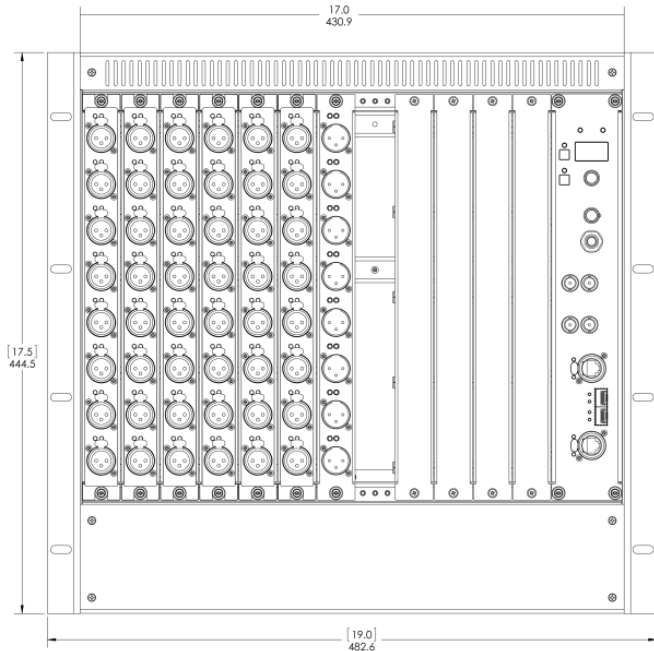

Parameter	Specification
Maximum Height	17.5 in (444.5 mm)
Rack Spaces	10U
Width with Rack Ears Width without Rack Ears	19 inches (483 mm) 17 inches (430.9 mm)
Maximum Depth	12.2 in (309.8 mm)

You can download DXF line drawings of all S6L hardware components from the [S6L Documentation](#) article on our Knowledge Base.

# Dimensions: Stage 48

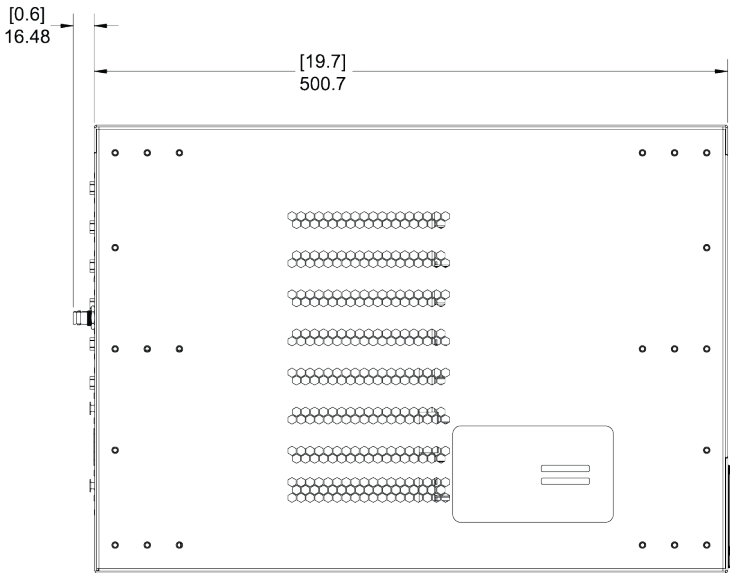
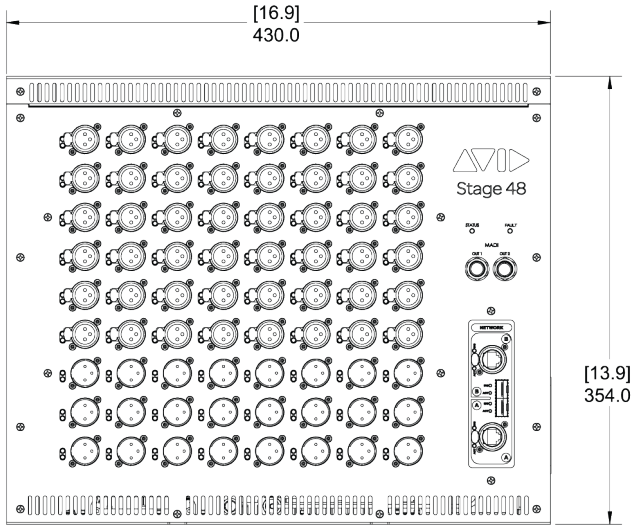

Parameter	Specification
Maximum Height	13.9 in (354.0 mm)
Rack Spaces	8U
Width with Rack Ears Width without Rack Ears	19 inches (483 mm) 17 inches (430.9 mm)
Maximum Depth	19.7 in (500.7 mm)

You can download DXF line drawings of all S6L hardware components from the [S6L Documentation](#) article on our Knowledge Base.



# Dimensions: Stage 32

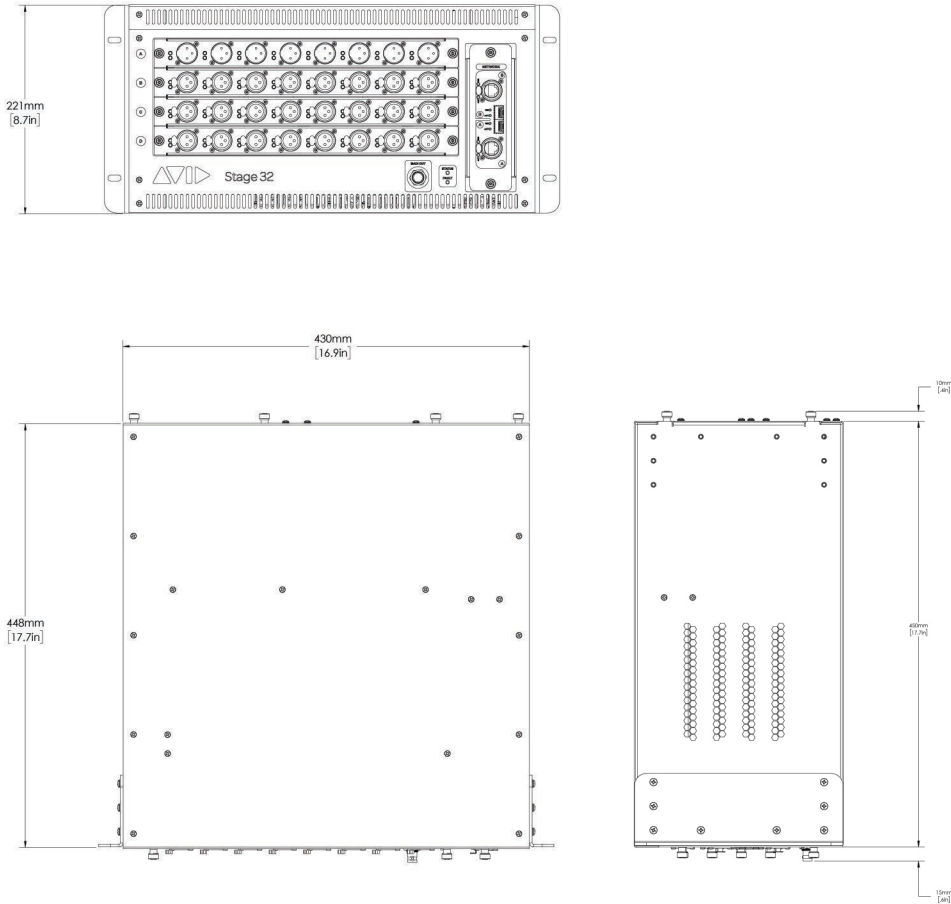

Parameter	Specification
Maximum Height	17.5 in (444.5 mm)
Rack Spaces	5U
Width with Rack Ears Width without Rack Ears	19 inches (483 mm) 17 inches (430.9 mm)
Maximum Depth	12.2 in (309.8 mm)

You can download DXF line drawings of all S6L hardware components from the [S6L Documentation](#) article on our Knowledge Base.

# Dimensions: Stage 16

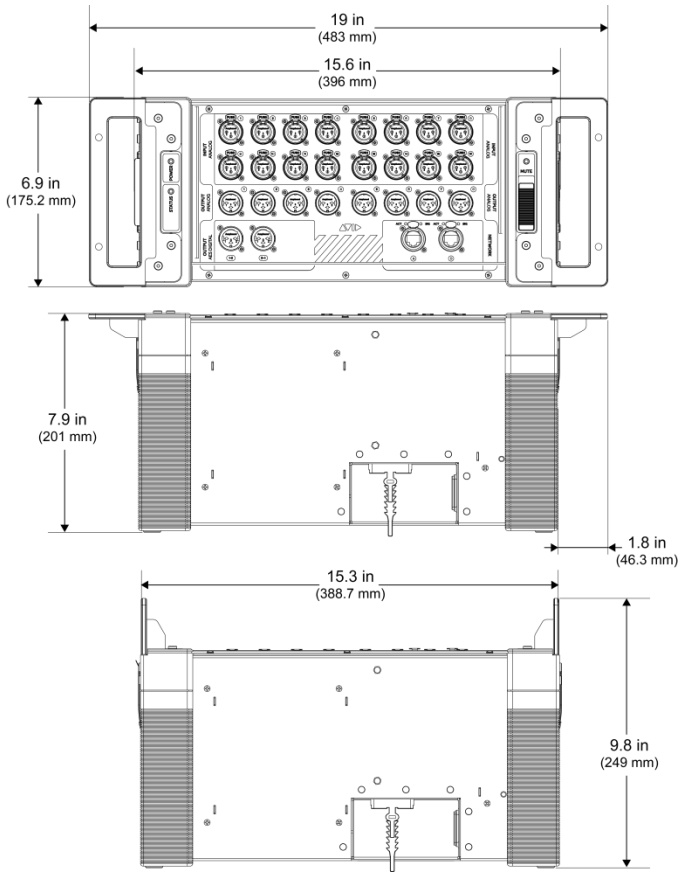

Parameter	Specification
<b>Maximum Height</b>	6.9 in (175.2 mm)
<b>Rack Spaces</b>	4U
<b>Width (with Rack Ears)</b> <b>Width (Rack Ears configured as handles)</b>	19 inches (483 mm) 15.6 inches (396 mm)
<b>Depth (with Rack Ears)</b> <b>Depth (Rack Ears configured as handles)</b>	7.9 in (201 mm) 9.8 in (249 mm)

You can download DXF line drawings of all S6L hardware components from the [S6L Documentation](#) article on our Knowledge Base.

# Dimensions: Local 16

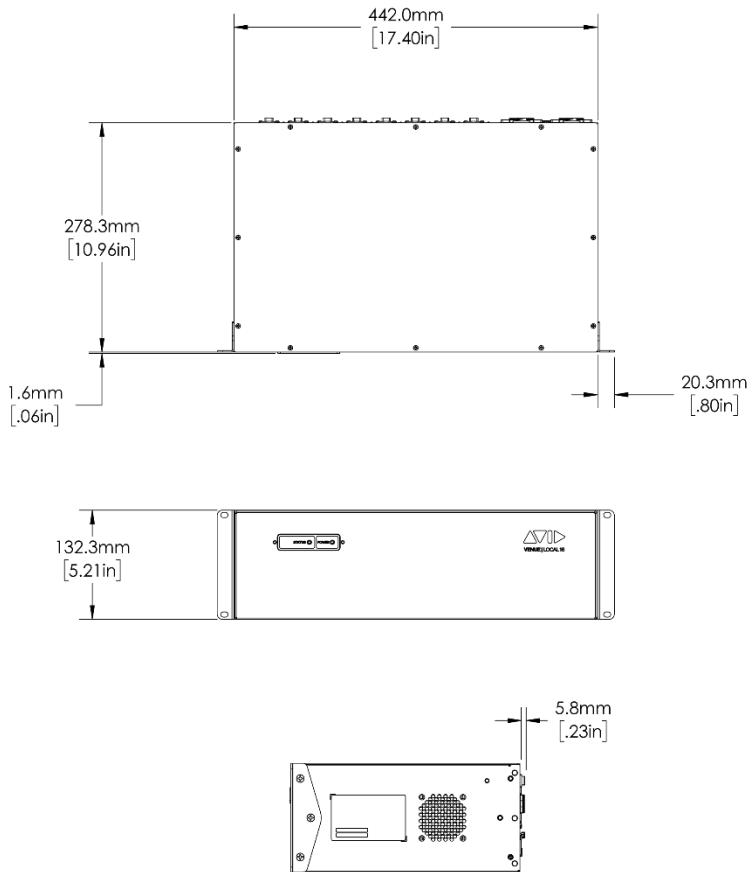

Parameter	Specification
<b>Maximum Height</b>	5.2 in (132 mm)
<b>Rack Spaces</b>	3U
<b>Width (with Rack Ears)</b> <b>Width (without Rack Ears)</b>	19 inches (483 mm) 17 inches (430.9 mm)
<b>Depth (with Rack Ears)</b>	11 in (278 mm)

You can download DXF line drawings of all S6L hardware components from the [S6L Documentation](#) article on our Knowledge Base.

# Cabling Requirements

## Power Connections

- Power connections on all S6L system devices are auto voltage-selecting (100 to 240V nominal, 90-260V maximal, 50–60 Hz).
- Make sure your power source is correctly rated for the number of units you are connecting. A surge-protected power source (not included) is highly recommended.

## Audio Network Connections

- A minimum of four (4) shielded Cat 5e (350 MHz) or better Ethernet cables are required for software installation and operation of a base configuration. One Ethernet cable is included with the S6L control surface, the other three (or more depending on the number of devices in the configuration) must be purchased separately.
- Audio network connections between S6L system components can be made using either copper or fiber-optic audio network cables. Cable types can be mixed within a system, but only one type of connection (copper or fiber) should be used per audio network port. Each *Network port* (A or B) has two *connectors* (one copper, and one fiber). Never have both copper and fiber connected to the same network port simultaneously.

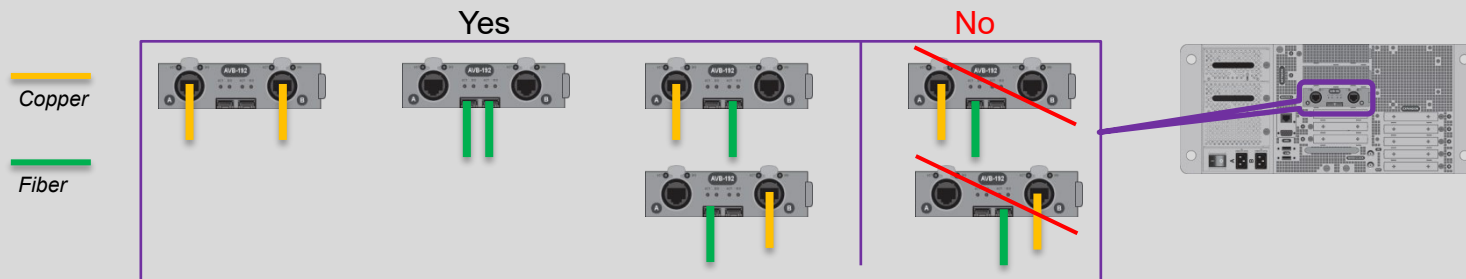

## Copper

- Shielded Cat 5e (350 MHz) or better Ethernet cable with Neutrik etherCON connectors required. Supports up to 100 meters per connection.

## Fiber-Optic

- S6L systems support single-mode fiber (SMF) or multi-mode fiber (MMF) cable to make audio network connections between components, as follows:
  - SMF** Requires single-mode 9/125 OS1 or OS2 cables with duplex LC connectors and two qualified single-mode SFP transceivers per connection, supporting distances of up to 10 kilometers.
  - MMF** Requires multi-mode 50/125 OM2 or better cables with duplex LC connectors and two qualified multi-mode SFP transceiver modules per connection, supporting distances of up to 500 meters.

## Pro Tools and VENUeLink Connections

- Shielded Cat 5e (350 MHz) or better Ethernet cable with RJ-45 connectors is required for AVB audio connections for Pro Tools and/or VENUeLink.

## ECx Ethernet Control Connections

- Standard Cat 5e Ethernet cable required.

For the most up-to-date list of requirements and supported cables, bookmark this article on our Knowledge Base: [Avid-S6L-Support](#)

# Other VENUE Systems

Follow this link for information about S3L-X/S3L systems:

[S3L-X](#)

